

AK6 Series temperature controller

Operation InstructionV1.06

Thank you for using Cautoni-Swastik AK6 series temperature controller. This instruction describes product function, features and proper usage. Before using, please pay special attention to issues below:

- User should master enough electric knowledge
- User must read and understand this instruction well for right usage
- Please consider applicability to system, machine and equipment
- Please note and observe the prohibition of this product
- The examples in this instruction or other data are only for user reference. No guarantee of a certain action.
- When using this controller with other products, please confirm whether it is in conformity with the relevant specifications, principles, etc..

A1

Content Index

A1	Content Index	B3	Menu display explanation
A2	Warning	C1	ALM alarm type define
A3	Notes	C2	ALM alarm parameter define
A4	Electric Specificaiton	C3	Input type selection
A5	Outer dimension	C4	PID control type selection
A6	AK6-A wiring	C5	Status information explanation
A7	Installation size	C6	Error display explanation
A8	AK6-B/AK6-D/AK6-E wiring	C7	Analog type define
A9	Panel functon explanation	C8	Other information
A10		D	Operation instruction

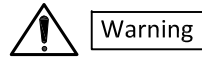

Warning

- ① To avoid electric shock, DON'T touch the AC power supply terminals after power on
- ② Before power on, please confirm voltage conformity in range of AC 85~265V, to avoid damage to controller
- ③ Never remove, retrofit or repair the product or contact any internal components
- ④ If the output relay exceeds its life span, the contacts may melt and burn.
- ⑤ Tighten screw with 0.74-0.90Nm torque, as loose screws may cause fire
- ⑥ Use appropriate fuse to ensure power supply line and input / output line to prevent current impact
- ⑦ Don't use the controller in occasion of flammable, explosive gas, discharge of steam

Note

- ① For heat radiation, leave space around the controller and do not jam the ventilation holes in the controller.
- ② Keep enough space between the controller and equipment which generates high frequency and surge
- ③ Connect wires correctly
- ④ Use the controller under rated load and power supply
- ⑤ Use standard grade of alcohol to clean the controller; don't use paint thinner or similar chemicals
- ⑥ Read and understand this instruction carefully before using the controller
- ⑦ Don't use the controller in case the front panel peels off or breaks

A3

Electric Specificaiton

rated voltage	180V~240V AC , 50HZ
power consumption	≤5VA
working environment	Ambient temperature: 0C ~50C Relative humidity: 35%~85% (no condensation)
Storage temperature	-25℃-65℃ (Avoid ice or dew)
Resolution	1℃, 0.1℃ (adjustable)
Wiring method	terminals
accuracy	±0.5%FS
Memory protection	Non-volatile memory
installation environment	Installation type II, pollution grade 2 (IEC61010-1)
relay output	relay contacts AC220V/DC30V, 3A
logic level output	ON:DC12V; OFF: below DC0.5V; Max current: 30mA; Load resistance≥1K.

A4 Model selection

Model selection

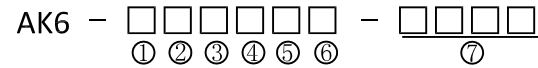

- ① Panel size
A: 48*48 B: 48*96 D: 72*72 E: 96*96
- ② Input signal
K:K. E. J. N. W3-25. W5-26 P:PT100 C:CU50 S:S. B. R. T
- ③ Power supply
L:Linear power supply
S:Switch power supply
- ④ Main output
1: relay 2: logic level
3: analog output 4: SCR phase shift / zero cross output
5: 30A relay output 6: Built-in SCR output
- ⑤ Alarm output
0: no alarm 1: 1 relay alarm output 2: 2 relay alarm outputs
3: 1 logic level alarm output and 1 relay alarm output
4:1 logic level alarm output 5:2 logic level alarm output
- ⑥ Strengthened function
0: No strengthened function
- ⑦ Function code
For customized product only

A5 Outer dimension and install hole size

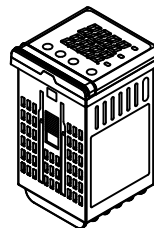

AK6-A

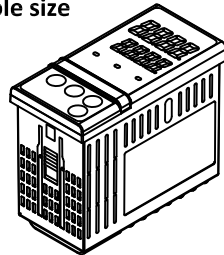

AK6-B

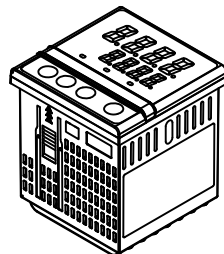

AK6-D

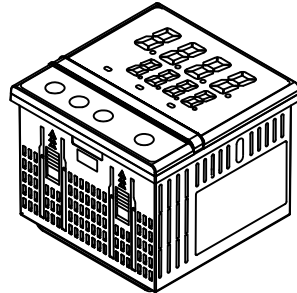

AK6-E

Unit: mm

Model	Panel size	case size LxWxH	install hole size
AK6-A	48×48	76×45×45	46×46
AK6-B	48×96	72×44×90	45×91
AK6-D	72×72	72×66×66	67×67
AK6-E	96×96	72×90×90	91×91

Wiring

A6

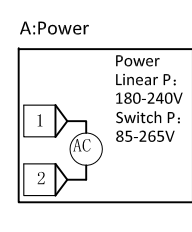
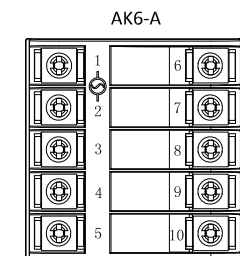

B:Main output

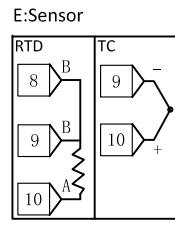
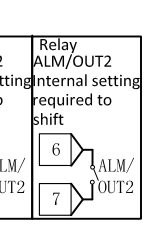
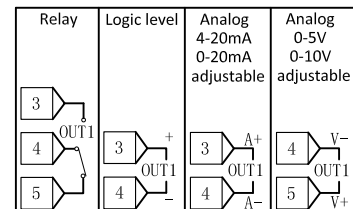

B1

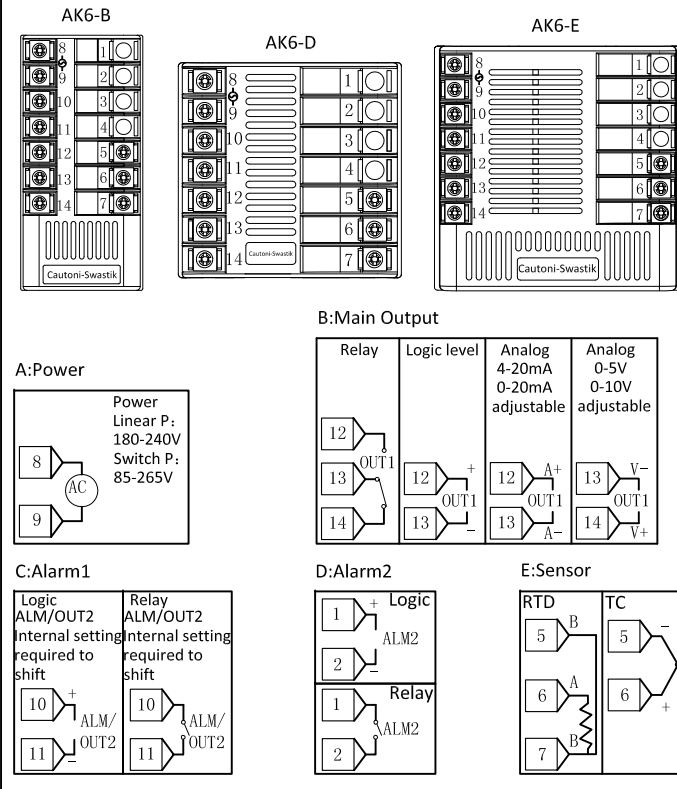

B2 Operation panel explanation

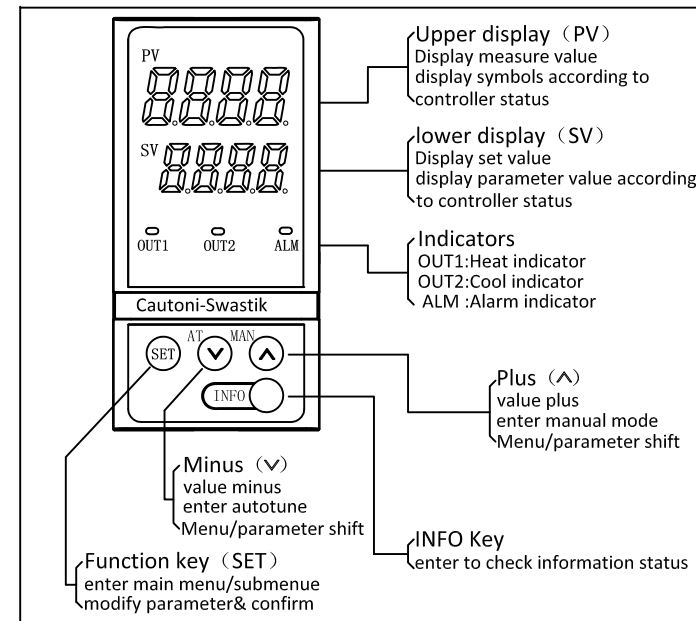

B3 Menu display explanation

Code	Menu Function	Default	Upper limit	Lower limit	Authority	Explanation
P00	data lock	0	900	0	0	0:0class authority 1:1class authority 18:2class authority 110:default to factory setting
P12	resolution	0	1	0	1	P12=0: No decimal point P12=1:decimal poin available
P13	temperature compensation	0	P32 value	P33 value	1	To modify temperature affected by sensor position or other problem
P16	input sensor	valid type	11	0	1	please refer to 《C2 Sesor selection》
P17	Alm1 mode	1	24	0	1	Alarm1 type please refer to 《B4 ALM alarm type define》
P18	upper limit of ALM1	10	P32 value	P33 value	1	
P19	Lower limit of ALM1	0	P32 value	P33 value	1	
P20	Alm1 parameter	0	7	0	1	The setting of ALM2 is the same as ALM1, please refer to 《B4 ALM alarm type define》
P22	Alm2 mode	0	24	0	2	
P23	upper limit of ALM2	0	P32 value	P33 value	2	
P24	Lower limit of ALM2	0	P32 value	P33 value	2	
P25	ALM2 Parameter	0	7	0	2	

Code	Menu Function	Default	Upper limit	Lower limit	Authority	Explanation
P28	manaul output value	0	100	-100	0	manaul output value
P30	error output value	0	100	-100	2	error output value
P31	℃/F shift	0	1	0	2	P31=0:℃ P31=1:℉
P32	Upper limit of set temperature for sensor	temperature range for sensor			2	Max temperature settable
P33	Lower limit of set temperature for sensor	temperature range for sensor			2	Min temperature settable
P36	Run time of motor	0.0	500.0	0.0	2	Run time of motor
P40	Brightness	4	7	0	2	only available with AK6-A series
P41	analog output mode	0	3	0	2	please refer to 《C6 analog mode define》
P42	analog output type	0	3	0	2	
P43	upper limit of temperature transmitting	0	P32 value	P33 value	2	
P44	lower limit of temperature transmitting	0	P32 value	P33 value	2	
P49	User variable	0	32767	-32768	0	User variable
P67	PID control mode	0	4	0	1	Please refer to 《C3 PID control mode selection》
P69	Dead zone vaule	0	Max	Min	2	Dead zone vaule
P70	Heat return difference	0.5	999.9	0	1	when P67=2, it is ON/OFF control . modify P70 to set heat return difference
P72	Auto tune AT	0	2	0	0	Automatically calculate most suitable PID parameter for customer's system.
P73	Overshoot suppression factor	0	20	0	2	Overshoot suppression factor
P74	Control intensity factor	1	3	0	2	Control intensity factor
P75	object model OBJ	0	5	0	2	object model
P76	Heat parameter P	10.0	Max	0.1	1	proportional band of heat
P77	Heat parameter I	240	Max	1	1	Integral time of heat (time for the next adjustment).
P78	Heat parameter D	60	Max	1	1	Derivative time of heat (time for advance adjustment)
P79	advance control value	5.0	10.0	0.1	2	start control in advance unit:degree
P80	heat cycle HT	20	100	1	1	Relay: 20 Logic level: 3
P87	min stop time	0	300	0	2	min stop time
P88	min start time	0	300	0	2	min start time
P89	Max output value	100	100	0	2	Max output value
P90	Min output value	-100	0	-100	2	Min output value
P91	Output variation	100	100	0	2	Output variation

Alarm

B4

ALM Alarm mode define - P17/P22

P17/P22 Code	Alarm Name	Alarm output condition
0	No alarm	No alarm output
1	Deviation upper limit	when PV>SV+P18
2	Deviation lower limit	when PV<SV-P19
3	Deviation upper & lower limit	when PV>SV+P18 or PV<SV-P19
4	Deviation upper & lower limit range	when PV<SV+P18 and PV>SV-P19
5	Deviation upper limit(keeping)	when PV>SV+P18
6	Deviation lower limit(keeping)	when PV<SV-P19
7	Deviation upper & lower limit(keeping)	when PV>SV+P18 or PV<SV-P19
8	Deviation upper & lower limit range(keeping)	when PV<SV+P18 and PV>SV-P19
9	absolute value upper limit	when PV> P18
10	absolute value lower limit	when PV<P19
11	absolute value upper & lower limit	when PV>P18 or PV<P19
12	absolute value upper & lower limit range	when PV<P18 and PV>P19
13	absolute value upper limit(keeping)	when PV> P18
14	absolute value lower limit(keeping)	when PV<P19
15	absolute value upper & lower limit(keeping)	when PV>P18 or PV<P19
16	absolute value upper & lower limit Range (keeping)	when PV<P18 and PV>P19
17	Upper limit with return difference	when PV>SV+P18 alarm on, till PV<SV-P19 alarm off

P17/P22 Code	Alarm Name	Alarm output condition
18	lower limit with return difference	when PV<SV-P19 alarm on, till PV>SV+P18alarm off
19	absolute value upper limit with return difference	when PV>P18 alarm on, till PV<P19 alarm off
20	absolute value lower limit with return difference	when PV<P19alarm on, till PV>P18 alarm off
21	Upper limit with return difference (keeping)	when PV>SV+P18alarm on,till PV<SV-P19alarm off
22	lower limit with return difference (keeping)	when PV<SV-P19 alarm on,till PV>SV+P18alarm off
23	absolute value upper limit with return difference (keeping)	when PV>P18alarm on, till PV<P19alarm off
24	absolute value lower limit with return difference (keeping)	when PV<P19 alarm on, till PV>P18 alarm off

ALARM KEEPING definition: after powering on the controller, PV should go out of the alarm range first, and when it goes back to the alarm range again, the alarm output would only be ON for the first time.

C1 ALM alarm parameter define - P20/P25		
P20/P25 Code	Parameter define	Explanation
0	None	no action
1	Alarm1 output (ALM1)	alarm output is set to ALM1
2	alarm 2 output (ALM2)	alarm output is set to ALM2
3	heat output	Shift heat output. details please refer to 《D Operation instruction》
4	cool output	cool output point of Two-way PID
5	Manual symbol	action symbol of manual output
6	Information symbol	settable output point when F.01≠0 in info menu, details please refer to 《C4 status information explanation》
7	Error symbol	settable output point when error happens, details please refer to 《C5 Error display explanation》

Remark: when set this parameter, corresponding P17 or P22 should be set to 0.

C2 Sensor input

sensor input	sensor type	set code	temperature range
K	K	0	-200℃—1200℃
	E	1	-200℃—650℃
	J	2	-200℃—850℃
	N	5	-200℃—1300℃
	W3-25	10	0℃—2300℃
P	PT100	8	-200℃—850℃
	C	9	-50℃—150℃
S	S	3	-50℃—1700℃
	B	4	0℃—1800℃
	R	6	-50℃—1700℃
T	7	-200℃—400℃	

C3 PID Control mode selection

P67 set value	0	1	2
mode	single PID	Two way PID (invalid with AK6 series)	ON/OFF Control

C4 Information status explanation

INFO Information status table			
Parameter code	Code define	Parameter code	Code define
F. 01	Info alarm code	F. 91	Manufacture month
F. 10	control output value	F. 92	Manufacture day
F. 11	cold end temperature (room temperature)	F. 93	Software version
F. 12	internal parameter	F. 94	PID bank version
F. 90	Manufacture year	F. 95	User version

C5 Error display explanation

Error code table			
display	code define	trouble shooting	Remark
Err0	No Error	None	Upper display (PV) blinks
Err1	parameter invalid	Controller malfunction, please contact supplier for service.	
Err2	RTD disconnected	Please check if RTD is disconnected.	
Err3	abnormal cold end temperature	Controller malfunction, please contact supplier for service.	
Err4	exceed upper limit of temperature range	Please check if thermocouple is disconnected.	
Err5	exceed lower limit of temperature range	Please check if thermocouple is disconnected.	

C6 Analog type define

Code	Parameter function	settable value	explanation	authority
P41	analog output mode	0 = analog output mode: 4-20mA 1 = analog output mode: 0-20MA 2 = analog output mode: 0-5V 3 = analog output mode: 0-10V default: 0	shiftable	2class
P42	analog output setting	0 = heat output value 1 = cool output value 2 = temperature transmitting output 3 = reversed heat output default: 0	0: analog output for heat control 1: Two-way PID mode, invalid for AK6 2: Analog output for temperature transmitting output 3: analog output reversed heat value for cooling	2class
P43	upper limit of temperature transmitting	temperature value for max analog	only valid in temperature transmitting mode	2class
P44	lower limit of temperature transmitting	temperature value for min analog	only valid in temperature transmitting mode	2class

C7 Other information

1. single side & double side wiring both available

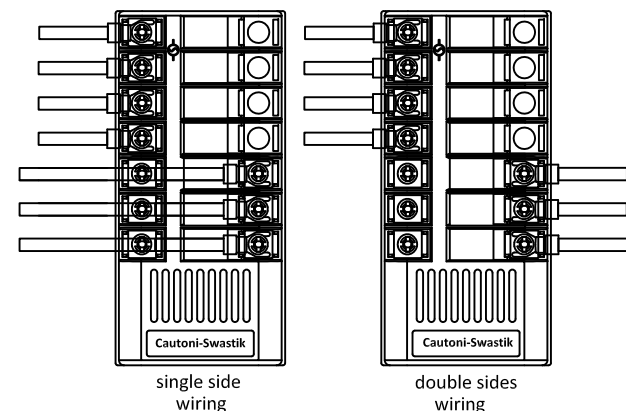

2. Convenient clip guide groove

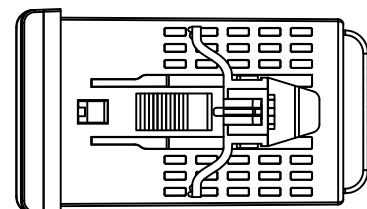

3. Difference of single PID and two-way PID

- * lower power consumption, higher control accuracy
- * PID control for both heating and cooling
- * Avoid temperature fluctuation caused by ON/OFF cooling
- * Cooling type changes into PID intelligent control from ON-OFF return difference control. This is huge progress like old analog controller changes into intelligent controller.

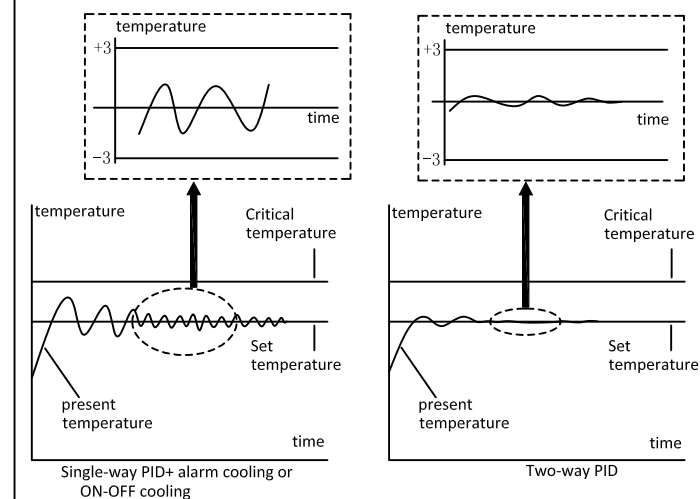

Remark: AK6 series doesn't have this function. if needed, please use GT8 series.

4. Comparison on anti-interference performance

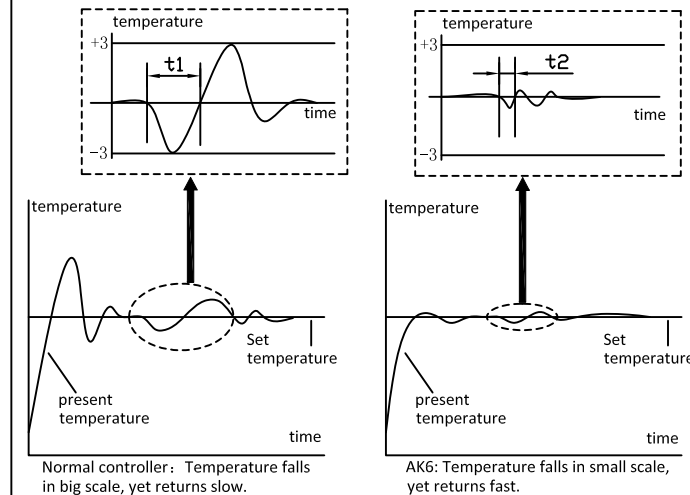

5. Comparison on start overshooting

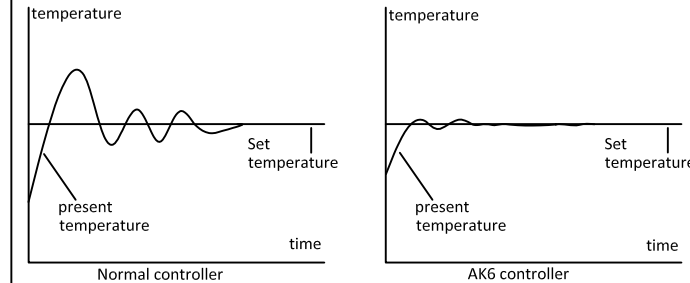

D Operation instruction

Temperature setting

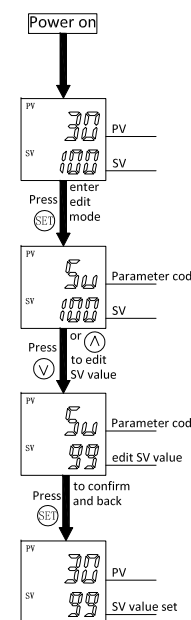

System parameter setting

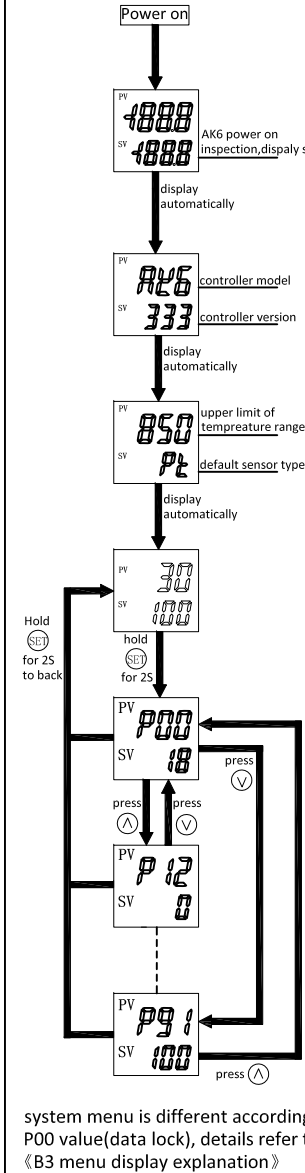

Autotune(AT) operation

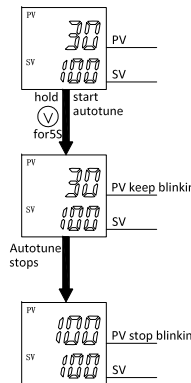

system menu is different according to P00 value(data lock), details refer to 《B3 menu display explanation》

Case: set upper limit alarm deviation 5℃

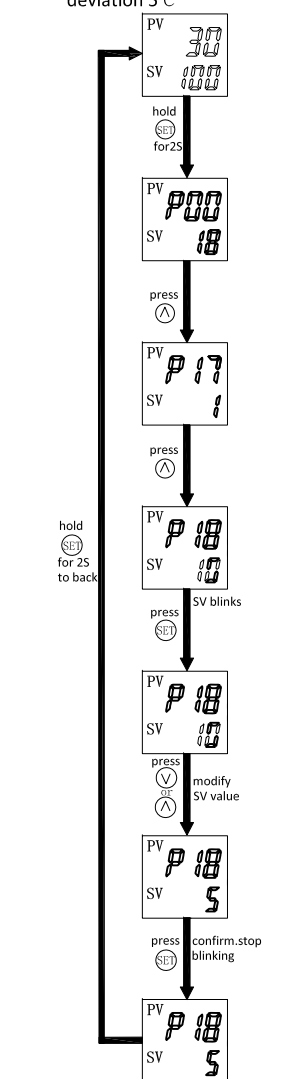

Remark: P17: Alm1 mode please refer to 《B4 ALM mode define》
P18:upper limit of alarm

Case: Shift sensor type

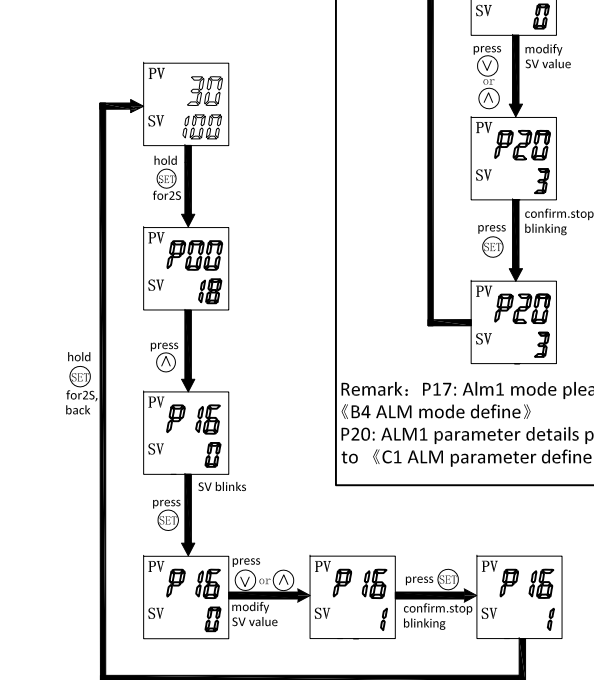

Remark: P17: Alm1 mode please refer to 《B4 ALM mode define》
P20: ALM1 parameter details please refer to 《C1 ALM parameter define》

Remark: P16:input sensor selection please refer to 《C2 input sensor selection》