

SUMO

Preface

Thank you for purchasing the SU200 series frequency inverter. The SU200 series frequency inverter is a general purpose high performance current vector control Inverter. It could implement the control of asynchronous motor and permanent magnet synchronous motor (PMSM). It increases the user programmable function, background monitoring software and communication bus function, and supports multi-kinds PG cards. It is used to drive various automation production equipment involving textile, paper making, wired drawing, machine tool, packing, food, fan and pump.

This manual describes the correct use of the SU200 series Inverter, including selection, parameter setting, commissioning, maintenance & inspection. Read and understand the manual before use and forward the manual to the end user.

Notes
<p>The drawings in the manual are sometimes shown without covers or protective guards. Remember to install the covers or protective guards as specified first, and then perform operations in accordance with the instructions.</p> <p>The drawings in the manual are shown for description only and may not match the product you purchased.</p> <p>The instructions are subject to change, without notice, due to product upgrade, specification modification as well as efforts to increase the accuracy and convenience of the manual. Contact our agents or customer service center if you have problems during the use.</p>

Page

Chapter 1 Safety requirement and cautions.....	3
Chapter 2 Product Information	5
2.1 SU200 brief introduction:	5
2.2 SU200 Inverter Designation Rules and Nameplate	5
2.3 SU200 related current and voltage	6
2.4 Technical specification	7
2.5 Product structure and Dimension.....	9
Chapter 3 Mechanical and Electrical Installation	11
3.1 Installation Environment.....	11
3.2 Installation space	11
3.4 Selection of Peripheral Electrical Devices of SU200	16
3.5 Installation and wiring	19
3.6 Main circuit terminals description.....	19
3.7 SU200 inverter diagram and terminals	20
Chapter 4 Operation control panel description.....	22
Chapter 5 Quality Guarantee	24
Chapter 6 Function Code Table	25
Chapter 7 Monitor parameters of Inverter.....	59
Chapter 8 Description of Function Codes	62
Chapter 9 EMC solution.....	115
9.1 Definition of Terms.....	115
9.2 Introduction to EMC Standard.....	115
9.3 Selection of Peripheral EMC Devices	116
9.4 Solutions to Common EMC Interference Problems	117
Chapter10 Maintenance and Troubleshooting	118
10.1 Routine Repair and Maintenance of the SU200	118
10.2 Warranty Agreement.....	119
10.3 Faults and Solutions	119
10.4 Solutions to the faults of the SU200 inverter.....	120
Chapter 11 SU200 RS485 communication protocol	124



Chapter 1 Safety requirement and cautions

Thanks for using SU200 high performance frequency inverter. Please read this manual carefully and fully understand the safety requirement and cautions before use (installation, wiring, operation, maintain, checking, and etc...).

Please do totally understand this part before using the inverter.

Warning signs and meanings

This manual has used below signs that mean there is an important part of security. While observing against the rules, there is danger of injury even death or machine system damage.

 Danger	Danger: Wrong operation may cause death or large accident.
 Warn	Warning: Wrong operation may cause death or large accident.
 Caution	Caution: Wrong operation may cause minor wound.
Important	Important: Wrong operation may cause the inverter and other machine system damage

Operation requirement



Only professional trained person are allowed to operate the equipment such as installation, wiring, running, maintain and etc. "Professional trained person" in this manual means the workers on this product must experience professional skill train, must be familiar with installation, wiring, running and maintain and can rightly deal with emergency cases in use.

Safety guidance



Safety regulations and warning signs come for your security. They are measures to prevent the operator and machine system from damage. Please carefully read this manual before using and strictly observe the regulations and warning signs while operating. Safety regulations and warning signs are classified into: routine regulation, transport and store regulation, installation and wiring regulation, running regulation, maintenance regulation, dismantlement and disposal regulation.

● Routine regulation



 Warn	<ul style="list-style-type: none"> ● This product carries dangerous voltage and controls driver machine with potential danger. If you don't abide by the regulations or requirements in this manual, there is danger of body injury even death and machine system damage. ● Only qualified personal are allowed to operate the equipment this product. Before using, the operator must be familiar with all safety specifications and operation regulations in this manual. Safe and stable work of the product is based on right operation and maintenance. ● Do not wire while the power is connected. Otherwise, there is danger of death for electric shock. Before wiring, inspection, maintenance, please cut power supply of all related equipment and ensure mains DC voltage in safe range. And please operate it after 5 minutes.
--	--

	<ul style="list-style-type: none"> ● Away from children and public. ● Only used in application fields as maker stated. No use in equipment related to special fields such as emergency, succor, ship, medical treatment, aviation, nuclear and etc. ● Unauthorized alteration or use of accessories which are not sold or recommended by the maker may cause faults.
	<ul style="list-style-type: none"> ● Please make sure this manual is in the end user's hand before using. ● Before installation and debugging please carefully read and totally understand these safety regulation and warning signs.

Transport and store regulation

	<ul style="list-style-type: none"> ● Correct transport, store, installation and careful operation a maintenance are important for inverter safe operation.
	<ul style="list-style-type: none"> ● In transport and store process, make sure the inverter is free from impact and vibration. It must be stored where is dry without corrosive air and conductive dust, and the temperature must be lower than 60°C.

Installation and wiring regulation

	<ul style="list-style-type: none"> ● Only professional trained person can operate it. ● Power wire, motor wire and control wire should be all connected firmly. Earth must be reliable and earth resistance must be lower than 10Ω. ● Before opening the inverter, please disconnect all related equipment power supply and make sure the mains DC voltage is in safe range and operate after 5mins. ● Human body electrostatic will damage inner sensitive components seriously. Before operation, please follow ESD measures. Otherwise, there is danger of inverter damage. ● Inverter output voltage is pulse wave. If components such as capacitor which improves power factor and pressure-sensitive resistance for anti-thunder and so on are installed at the output side, please dismantle them or change to input side. ● No switch components such as breaker and contactor at the output side. (If there must be one, please make sure the output current is 0 while the switch acting).
	<ul style="list-style-type: none"> ● The power supply cable and motor cable specifications must satisfy all conditions.

● Run regulation

	<ul style="list-style-type: none"> ● Inverter runs at high voltage. So dangerous voltage is in some components inevitably. ● No matter where the fault is, there is danger of serious accident, even human body injury what means dangerous malfunction possibility. So there must be additional external prevent measures or other safety devices, such as independent current limiting switch and so on.
---	--

● Maintenance regulation

	<ul style="list-style-type: none"> ● Any defective components must be changed in time. ● Before opening the inverter to repair please cut power supply of all related device and ensure mains DC voltage in safe range. And please do operation after 5 minutes.
---	--

Chapter 2 Product Information

2.1 SU200 brief introduction:

1. SU200 is a high reliability and high software performance motor drive with rich and perfect software and hardware functions to meet the application needs of most industrial sites;
2. SU200 can drive asynchronous motor and permanent magnet synchronous motor(PMSM) simultaneously. It could run with vector control without PG card, vector control with PG card, speed/torque control and position servo control.
3. Adopt advanced software vector control algorithm, which can provide high performance open loop vector control for asynchronous motor and synchronous motor. Meanwhile, simple vector control of asynchronous motor and synchronous motor can be used to meet the requirements of general speed adjustment application.
4. Built-in PID controller, the improved PID function can satisfy most of the on-site process control, such as the closed-loop control of temperature, pressure and flow.
5. Multiple protection function to ensure the safety of the drive and motor.
6. Standard 485 communication interface, support Modbus/RTU communication protocol, direct and upper computer communication for field bus control; Profibus-DP and CAN function also optional.

2.2 SU200 Inverter Designation Rules and Nameplate

2.2.1 Designation Rules

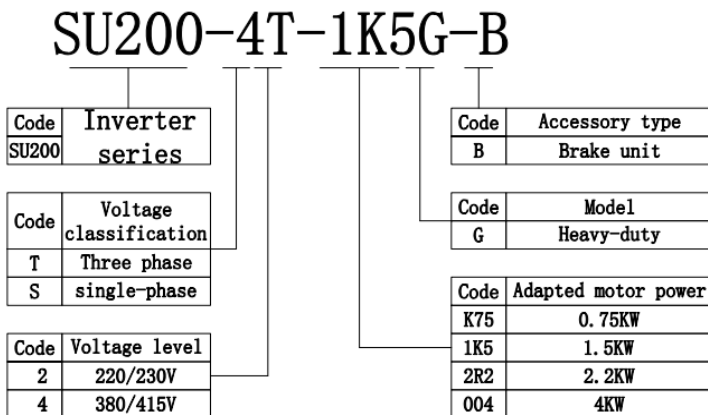

2.2.2 Nameplate

SUMO		Frequency Inverter	
MODEL:	SU200-4T-022GB/30PB		
INPUT:	3PH AC380V±15% 46.5A 50Hz/60Hz		
OUTPUT:	3PH AC 0-415V 46A 0-300Hz		
S/N:			
Website:			

2.3 SU200 related current and voltage

Single phase 220V, 50/60Hzinput				
Inverter models	Rated power(KVA)	Input current A	Output current A	For rated power of motor KW
SU200-2S-0.4GB	1.0	5.4	2.3	0.4
SU200-2S-0.7GB	1.5	8.2	4	0.75
SU200-2S-1.5GB	3.0	14	7	1.5
SU200-2S-2.2GB	4.0	23	9.6	2.2
SU200-2S-4.0GB	5.0	20.5	17	4.0
SU200-2S-5.5GB	7.0	26	25	5.5
3phase 380V/415V, 50/60Hz				
Inverter models	Rated power(KVA)	Input current A	Output current A	For rated power of motor KW
SU200-4T-0.7GB	1.5	3.4	2.1	0.75
SU200-4T-1.5GB	3	5	3.8	1.5
SU200-4T-2.2GB	4	5.8	5.1	2.2
SU200-4T-4.0G/5.5PB	5.9	10.5	9	3.7
SU200-4T-5.5G/7.5PB	8.9	14.6	13	5.5
SU200T7.5G/11PB	11	20.5	17	7.5
SU200-4T-11G/15PB	17	26	25	11
SU200-4T-15G/18.5PB	21	35	32	15
SU200-4T-18.5G/22PB	24	38.5	37	18.5
SU200-4T-22G/30PB	30	46.5	45	22
SU200-4T-30G/37P	40	62	60	30
SU200-4T-37G/45P	57	76	75	37
SU200-4T-45G/55P	69	92	91	45
SU200-4T-55G/75P	85	113	112	55
SU200-4T-75G/90P	114	157	150	75
SU200-4T-90G/110P	134	180	176	90
SU200-4T-110G/132P	160	214	210	110
SU200-4T-132G/160P	192	256	253	132

SUMO SU200 High Performance Vector Control Frequency Inverter

SU200-4T-160G/185P	210	307	304	160
SU200-4T-185G/200P	230	357	350	185
SU200-4T-200G/220P	250	385	377	200
SU200-4T-220G/250P	280	220	380	220
SU200-4T-250G/280P	355	250	470	250
SU200-4T-280G/315P	396	310	530	280
SU200-4T-315G/355P	455	498	600	315
SU200-4T-355G/400P	500	624	660	355
SU200-4T-400G/450P	560	680	690	400
SU200-4T-450G/500P	630	755	770	450
SU200-4T-500G/560P	700	840	860	500

2.4 Technical specification

Items		Specification		
Control mode	Control mode	V/F control	Sensorless in open loop	Close loop vector control
	Starting torque	0.5Hz 150%	0.5Hz 180%	0.00Hz 180%
	Speed adjust range	0: 50	1:100	1:1000
	Speed stabilizing precision	±1%	±0.1%	±0.02%
	Torque precision	NO	NO	±5%
	Motor type	General induction motor permanent magnet synchronous motor (PMSM)		
Function design	Highest frequency	General vector control :320Hz V/f control: 3200Hz		
	frequency resolution	Digital setting: 0.01Hz Analog setting:maximum×0.025%		
	Carrier frequency	0.5K ~ 16KHz, the carrier frequency can be adjusted by temperature automatically		
	Frequency reference setting method	Digital of Control panel, analog AI1, AI2, potentiometer of control panel, UP/DN control, communication, PLC pulse frequency		
	Acceleration./deceleration characteristic	Linear curve and S curve accel. /decel. mode, range of time: 0.0 to 65000S.		
	V/F curve	3 mode: linear, multiple points, N Power		
	V/F separation	2 times separation: totally separation, half separation		
	DC braking	DC braking frequency: 0.0 to 300Hz, DC braking current: 0.0% to 100%		
	Braking unit	Standard built in for up to 4T22G (22kw), optional built it for 4T30G ~ 4T110G (30kw to 110kw), external built for above 4T160kw .		
	Jog function	Job frequency range: 0.0 to 50.0Hz, the acceleration and deceleration time of Jog		
	Configured PID function	Easy to perform pressure, flow, temperature close loop control.		

SUMO SU200 High Performance Vector Control Frequency Inverter

<i>Items</i>		<i>Specification</i>
	PLC multiple speed	To achieve 16 segment speed running through built in PLC or terminal control
	Common Dc bus	Multiple drives use one DC bus for energy balance.
	Auto voltage regulation (AVR)	Enable to keep output voltage constant when grid fluctuation
	Over load tolerance capability	G type model: 150% rated current for 60s, 180% rated current for 3s, P type Model: 120% rated current for 60s, 150% rated current for 3s.
	Stall protection control when over current, over voltage	Carry out limiting automation for running current, voltage to prevent over current, over voltage frequently
	Rapid current limit function	Minimize the IGBT module broken to protect the Inverter, maximum reduce the over current fault.
	Torque limit and torque control	"Excavator" characteristics , torque limit automatically during motor running. Torque control is available in close loop vector control mode.
Features	Friendly interface	Display "Hello" when power on.
	Multiple function key JOG button	It can set for Forward Jog, reverse Jog, forward/reverse switch
	Timing control function	A total running time and total running time calculating
	2 group motor parameters	To achieve two motor switchover freely, control mode is selectable
	Motor over heat protection	Accepting motor temperature sensor signal input via AI1 terminals.
	Multiple kinds encoder *	Compatible collector PG, differential PG, and rotary transformer Encoder(resolver).
	Command source	Control panel, control terminals, series communication, switch freely.
	Frequency source	Digital setting, analog current/voltage, pulse setting, serial communication, main and auxiliary combination.
Environment	Protection function	Short circuit detect when power on, input/output phase loss, over voltage, over current, under voltage, over heat, over load protection.
	Application site	Indoor, free of exposure to sunlight, no dusty, no corrosive, no inflammable gas, no oil and water vapor, and water dipping
	Altitude	Lower 1000m
	Environment temperature	-10℃ ~ +40℃, power derated for 40 ~ 50℃, rated current derated 1% for 1℃ increasing.
	humidity	Less than 95%, no water condense.
	storage	-40 ~ +70℃
	IP degree	IP20

2.5 Product structure and Dimension

SU200M mini frequency inverter dimension



Mini type Fig 1

Power	H	H1	W	W1	D	D1	Hole
0.4~1.5KW	130	132	85	74	123.5	74	4.5
2.2kw (220V)	151	142	100	88	127	789	5.4

SU200 general frequency inverter dimension

Inverter models	Installation lot mm		External dimension mm				Mm	GW kg
	A	B	H	H1	W	D		
2S, 220V, 50/60Hz								
SU200-2S-0.4GB	106.5	175	185	/	118	165.5	4.5	2.3
SU200-2S-0.75GB								
SU200-2S-1.5GB								
SU200-2S-2.2GB								
SU200-2S-4.0GB	148	235	247	/	160	189.5	5.5	4.0
4T , 380V, 50/60Hz								
SU200-4T-0.7GB	106.5	175	185	/	118	165.5	4.5	2.3
SU200-4T-1.5GB								
SU200-4T-2.2GB								
SU200-4T-4.0GB/5.5PB								

SUMO SU200 High Performance Frequency Inverter

SU200-4T-5.5GB/7.5PB	148	235	247	/	160	189.5	5.5	4.0
SU200-4T-7.5GB/11PB								
SU200-4T-11GB/15PB								
SU200-4T-15GB/18.5PB	205	305	320	/	220	197.3	6.5	6.8
SU200-4T-18.5GB/22PB								
SU200-4T-22GB/30PB	170	400	415	395	230	205	6.5	11
SU200-4T-30G/37P	200	465	480	460	260	227.5	8	17
SU200-4T-37G/45P								
SU200-4T-45G/55P	180	550	575	555	320	310	10	36
SU200-4T-55G/75P								
SU200-4T-75G/90P	240	595	620	600	380	310	10	49
SU200-4T-90G/110P								
SU200-4T-110G/132P								
SU200-4T-132G/160P	380	800	825	/	500	350	11	/
SU200-4T-160G/185P								
SU200-4T-185G/200P								
SU200-4T-200G/220P								

Chapter 3 Mechanical and Electrical Installation

3.1 Installation Environment

1. Ambient temperature, the surrounding environment temperature take great effect for service life span of solar pump inverter, don't allow surrounding temperature over than allowable temperature above (-10°C to +50°C)
2. Heat dissipation, Install the solar drive on the surface of an incombustible object, and ensure that there is sufficient space around for heat dissipation. Install the solar pump inverter vertically on the support using screws.
3. Vibration, it should be less than 0.6G, far away from the punching machine or the like.
4. Free from direct sunlight, high humidity and condensation
5. Free from corrosive, explosive and combustible gas
6. Free from oil dirt, dust and metal powder

3.2 Installation space

Single machine installation: to ensure enough ventilation and wiring space for inverter cooling, please follow installation conditions as follows.

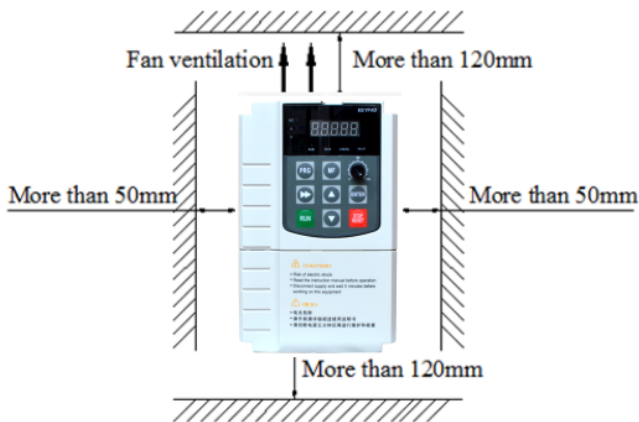



SU200 installation space requirement

3.3 The connection between SU200 and peripheral devices

3.3.1 Safety rules







User must obey to the following safety rules and related requirements while using the peripheral equipment and options.

	<ul style="list-style-type: none"> ● No operation under power connected state. Otherwise there is danger of electric shock death. ● Before operation, please cut all related equipment power, ensure that the main circuit DC current has drop to safe range. And please operate after 5 mins.
	<ul style="list-style-type: none"> ● No operation while cover/panel is dismantled. Otherwise there is danger of electric shock death. ● Do not dismantle the cover or PCB under power connected state.







	<p>Otherwise there is danger of electric shock death.</p> <ul style="list-style-type: none"> ● Only professional person can install, debug or maintain the peripheral equipment and options. Otherwise there is danger. ● Do not wear loose clothes while install, debug, maintain. Rated protective tools and safeguard should be adopted. ● Do not change wire, dismantle jumping wire, optional card, or change cooling fan while the inverter is running. Otherwise there is danger of electric shock death. ● Tighten screw according to named moment. If main circuit wire connection is loose, there is danger of overheat fire. ● Earth of the peripheral equipment and options must be reliable to prevent human body injury.
<div style="border: 1px solid black; padding: 5px; width: fit-content; margin: auto;">Important</div>	<ul style="list-style-type: none"> ● While operation, please follow the ESD regulations. Otherwise the inverter may be damaged. ● Do not cut the power supply while the inverter is outputting voltage. Otherwise the inverter may be damaged.

3.3.2 Peripheral devices

Normal peripheral equipment are showed as below. To order the peripheral equipment, please consult our dealer or sales department.

Peripheral equipment		Functions
	Breaker	Protect power system and prevent malfunction impact other equipment working when short-circuit happens. And over-load protection.
	Leakage current breaker	Earth protection prevent electric shock(suggest to use the type which can prevent high-frequency leakage current)
	Electromagnetic contactor	Separate power and inverter indeed and realize basic relay control.
	AC input reactor	Improve power side factor and isolate the noise disturbance to the frequency inverter from the power side.
	DC reactor	Restrain ultraharmonics and improve power factor.
	Input side noise filter	Reduce frequency inverter disturbance to the power and reduce the power grid disturbance.
	Braking resistor	Passive energy consume unit of electric braking.

SUMO SU200 High Performance Frequency Inverter

	Consumption braking unit	Electric braking control unit, controlling the braking resistance consume the regenerated electric power of the motor efficiently.
	Output side noise filter	Reduce the output side wire electromagnetic disturbance.
	Standby system	Standby system for inverter malfunction.
	Heat relay	Protect the motor while over load.
	0-phase reactor	Reduce electromagnetic disturbance of the frequency inverter (suitable for input/output side).
	Main loop surge absorbable unit	Restrain surge voltage while main loop switch components act.
	Winding surge absorbable unit	Restrain surge voltage when the AC contactor acts.

3.3.3 The use of peripheral devices

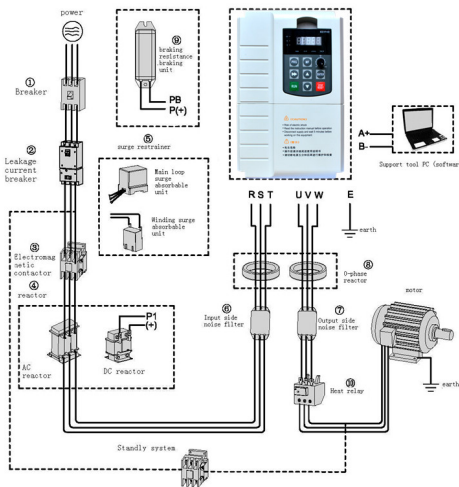

Chart 3-1:Peripheral equipment connection

Note:

Wiring breaker

To ensure wiring safe, protect power system and prevent malfunction expand to impact other equipment working while short-circuit happens, and protect while over-load, please do use wiring breaker between power supply and main loop power input terminals R,S,T.



:While choosing the breaker, the capacitance should be 1.5-2 times of the rated output current of the frequency inverter. Please compare the time characteristic and protective time to the inverter (150% of the rated output current, one minute). Make sure there will be no skip.



:Before main loop wiring, make sure to cut the breaker and electromagnetic contactor. Otherwise there is danger of electric shock.

Leakage current breaker

The frequency inverter outputs peak voltage high-speed switch square wave. So there is high-frequency leakage current. For earth protection to prevent electric shock and leakage current fire, please install leakage current breaker. Usually, one set frequency inverter will bring 100mA leakage current (while the power cable length is 1m). If the length prolongs 1m, there will be 5mA more leakage current. So please use leakage current breaker special for high frequency leakage at the power input side of the frequency inverter. The factors which impact leakage current are as below:

Capacitance of inverter

Carrier frequency

Motor cable type and wire length

MI/RFI filter

To protect human body and inverter, please choose leakage current breaker which can use AC/DC power and can face high frequency leakage current. There should be one leakage current breaker with more than 200mA sensitive current for every frequency inverter. If the frequency inverter outputs different wave, the high frequency leakage current can be higher, what will make the breaker misact. At this case, please take below treatments:

Improve the sensitive current of the leakage current breaker

Reduce the carrier frequency of the inverter

Electromagnetic contactor

Electromagnetic contactor is a peripheral equipment what is set to actually separate power and inverter connection. While inverter protective function is acting or carry out emergency stop operation, the main loop power can be cut by peripheral equipment. Please do not connect the electromagnetic switch or electromagnetic contactor to output circuit. Otherwise the inverter maybe damaged. While the power recovers after instant stop, if it needs to prevent the inverter to auto-restart, please install electromagnetic contactor for control at the input side.

AC input reactor and DC reactor

To restrain current sharp change and high hypo harmonic current, it needs to use AC input reactor and DC reactor. It can also improve power factor at the input side. In the bellowing cases, AC input reactor or DC reactor must be used (use both will bring better effect).

Need to restrain high hypo harmonic current and improve power side factor;

Need to switch input phase capacitance;

Frequency inverter is connected to large capacitance power transformer (600kVA above); Silicon-controlled converters such as DC motor driver are connected to the same power system.

The DC reactor, whose parameters are designed only for individual odd harmonic. If user has higher requirement on other harmonic restraint, please connect the external DC reactor.

Before connect the external DC reactor, make sure to dismantle the short connector between the terminals PB and (+).

Surge restrainer

Surge restrainer is divided to winding surge restrainer and main loop surge restrainer according to the use position. Please choose the right one which is suitable for the occasion. The aim of surge restrainer installation is to restrain the surge voltage brought by switch components such as inductive load which is surrounding the frequency inverter (electromagnetic contactor, electromagnetic relay, electromagnetic valve, electromagnetic winding, electromagnetic detent). Do not connect the surge restrainer to the output side of the frequency inverter. Otherwise the frequency inverter will be damaged.。

Input side noise filter

Rectifier bridge of the inverter is uncontrolled rectifier bridge. And input current is discontinuous impulse current. So the harmonic current noise signal, what flows to power wire from the inverter inner, maybe bring bad impact on the surrounding machines (radio, phone, noncontact switch, sensor). This time, we suggest to install input side noise filter to lighten the noise into the power wire. Besides, it can also reduce noise from the power wire into the frequency inverter.



:Please use the noise filter special for the frequency inverter and the connection wire between the filter and the inverter should be as short as could.

Output side noise filter

The frequency inverter outputs square wave with high-speed peak value voltage switch. So there is high-speed dv/dt converter on the output cables that will produce a large number of radio disturbance and inductive signal. By installation noise filter at the output side, the impact can be relieved. Please do not install the input-phase capacitance and the noise filter to the output circuit. Otherwise there is danger of damage to the frequency inverter.

0-phase reactor

0-phase reactor is used to reduce the electromagnetic inductive disturbance of the frequency inverter, which is suitable for the input side and output side. It equals to a three-phase common mode inductance. In actual use, according to the actual magnetic core size and cable specification, it is better to make sure 3-5 circles winding ratio to bring the best performance.

Braking reactor or braking unit

Renewed power consumption unit, please see the sixth part of the chapter 3.4 Selection of Peripheral Electrical Devices of SU200

3.4 Selection of Peripheral Electrical Devices of SU200

3.4.1 Selection of peripheral electrical devices

Inverter Model	MCCB	Contactor	Cable of Input Side Main Circuit	Cable of Output Side Main Circuit	Cable of Control Circuit
	(A)	(A)	(mm ²)	(mm ²)	(mm ²)
	Single-phase 220 V				
SU200-S0.7GB	10	12	0.75	0.75	0.5
SU200-S1.5GB	16	18	1.5	1.5	0.5
SU200-S2.2GB	25	25	2.5	2.5	0.5
SU200-S4.0GB	32	32	4	4	0.75
Three-phase 380 V					
SU200-4T-0.7GB	4	9	0.75	0.75	0.5
SU200-4T-1.5GB	6	9	0.75	0.75	0.5
SU200-4T-2.2GB	10	12	0.75	0.75	0.5
SU200-4T-4.0GB/5.5PB	16	18	1.5	1.5	0.5
SU200-4T-5.5GB/7.5PB	20	25	2.5	2.5	0.75
SU200-4T-7.5GB/11PB	25	25	4	4	0.75
SU200-4T-11GB/15PB	32	32	6	6	0.75
SU200-4T-15GB/18.5PB	40	40	6	6	0.75
SU200-4T-18.5G/22P	50	50	10	10	1
SU200-4T-22G/30P	50	50	10	10	1
SU200-4T-30G/37P	63	63	10	10	1
SU200-4T-37G/45P	80	80	25	25	1
SU200-4T-45G/55P	100	115	35	35	1
SU200-4T-55G/75P	125	125	50	50	1
SU200-4T-75G/90P	160	185	70	70	1
SU200-4T-90G/110P	200	225	95	95	1
SU200-4T-110G/132P	225	225	120	120	1
SU200-4T-132G/160P	315	330	120	120	1
SU200-4T-160G/185P	350	400	150	150	1
SU200-4T-185G/200P	350	400	150	150	1
SU200-4T-200G/220P	400	400	185	185	1
SU200-4T-220G/250P	500	500	240	240	1
SU200-4T-250G/280P	500	500	120 *2	120 *2	1
SU200-4T-280G/315P	630	630	120 *2	120 *2	1
SU200-4T-315G/355P	630	630	150 *2	150 *2	1
SU200-4T-355G/400P	700	800	185*2	185*2	1
SU200-4T-400G/450P	800	800	240*2	240*2	1
SU200-4T-450G/500P	800	800	240*2	240*2	1
SU200-4T-500G/560P	800	800	240*2	240*2	1

SUMO SU200 High Performance Frequency Inverter

In theory, the power of the braking resistor is consistent with the braking power. But in consideration that the de-rating is 70%, you can calculate the power of the braking resistor according to the formula $0.7 \times Pr = Pb \times D$.

Pr refers to the power of resistor.

D refers to the braking frequency (percentage of the regenerative process to the whole working process)

Application	Elevator	Winding and unwinding	Centrifuge	Occasional braking load	General application
Braking Frequency	20%–30%	20%–30%	50%–60%	5%	10%

You can select different resistance and power based on actual needs. However, the resistance must not be lower than the recommended value. The power may be higher than the recommended value.

The braking resistor model is dependent on the generation power of the motor in the actual system and is also related to the system inertia, deceleration time and potential energy load. For systems with high inertia, and/or rapid deceleration times, or frequent braking sequences, the braking resistor with higher power and lower resistance value should be selected.

3.4.2 Selection of Power of Braking Resistor

Recommended values of braking resistor

Model	Recommended Power	Recommended Resistance	Braking Unit
Single-phase 220 V			
SU200-S-0.7GB	80 W	$\geq 200 \Omega$	Built-in
SU200-S-1.5GB	80 W	$\geq 150 \Omega$	Built-in
SU200-S-2.2GB	100 W	$\geq 100 \Omega$	Built-in
SU200-S-4.0GB	100 W	$\geq 70 \Omega$	Built-in
Three-phase 380 V			
SU200-4T-0.7GB	150 W	$\geq 300 \Omega$	Built-in
SU200-4T-1.5GB	150 W	$\geq 220 \Omega$	Built-in
SU200-4T-2.2GB	250 W	$\geq 200 \Omega$	Built-in
SU200-4T-4.0GB/5.5PB	300 W	$\geq 130 \Omega$	Built-in
SU200-4T-5.5GB/7.5PB	400 W	$\geq 90 \Omega$	Built-in
SU200-4T-7.5GB/11PB	500 W	$\geq 65 \Omega$	Built-in
SU200-4T-11GB/15PB	800 W	$\geq 43 \Omega$	Built-in
SU200-4T-15GB/18.5PB	1000 W	$\geq 32 \Omega$	Built-in
SU200-4T-18.5G/22P	1300 W	$\geq 25 \Omega$	Built-in
SU200-4T-22G/30P	1500 W	$\geq 22 \Omega$	Built-in
SU200-4T-30G/37P	2500W	$\geq 16 \Omega$	External Optional
SU200-4T-37G/45P	3.7 kw	$\geq 16 \Omega$	External Optional
SU200-4T-45G/55P	4.5kw	$\geq 16 \Omega$	External Optional
SU200-4T-55G/75P	5.5 kw	$\geq 8\Omega$	External Optional
SU200-4T-75G/90P	7.5 kw	$\geq 8\Omega$	External Optional
SU200-4T-90G/110P	4.5kw*2	$\geq 8 \Omega^*2$	External Optional
SU200-4T-110G/132P	5.5 kw*2	$\geq 8 \Omega^*2$	External Optional
SU200-4T-132G/160P	6.5kw*2	$\geq 8 \Omega^*2$	External Optional
SU200-4T-160G/185P	16kw*2	$\geq 2.5 \Omega$	External Optional

SUMO SU200 High Performance Frequency Inverter

SU200-4T-185G/200P	16kw*2	$\geq 2.5 \Omega$	External Optional
SU200-4T-200G/220P	20kw	$\geq 2.5 \Omega$	External Optional
SU200-4T-220G/250P	22kw	$\geq 2.5 \Omega$	External Optional
SU200-4T-250G/280P	12.5 kW x 2	$\geq 2.5 \Omega \times 2$	External Optional
SU200-4T-280G/315P	14 kW x 2	$\geq 2.5 \Omega \times 2$	External Optional
SU200-4T-315G/355P	16 kW x 2	$\geq 2.5 \Omega \times 2$	External Optional
SU200-4T-355G/400P	17 kW x 2	$\geq 2.5 \Omega \times 2$	External Optional
SU200-4T-400G/450P	14 kW x 3	$\geq 2.5 \Omega \times 3$	External Optional
SU200-4T-450G/500P	14 kW x 3	$\geq 2.5 \Omega \times 3$	External Optional
SU200-4T-500G/560P	14 kW x 3	$\geq 2.5 \Omega \times 3$	External Optional

3.4.3 Selection of Reactor

SU200	Input AC reactor		Output Ac reactor		DC reactor
	Current (A)	Inductance value(mH)	Current (A)	Inductance value(mH)	Current (A)
380v model					
SU200-4T-0.7GB	5	3.8	5	1.5	/
SU200-4T-1.5GB	5	2.8	5	1.4	3
SU200-4T-2.2GB	7	1.4	7	0.7	6
SU200-4T-4.0GB/5.5PB	10	0.934	10	0.467	12
SU200-4T-5.5GB/7.5PB	15	0.934	15	0.467	/
SU200-4T-7.5GB/11PB	20	0.7	20	0.35	23
SU200-4T-11GB/15PB	30	0.47	30	0.233	/
SU200-4T-15GB/18.5PB	40	0.36	40	0.175	30
SU200-4T-18.5G/22P	50	0.28	50	0.14	40
SU200-4T-22G/30P	60	0.23	60	0.117	50
SU200-4T-30G/37P	80	0.17	80	0.087	60
SU200-4T-37G/45P	110	0.12	110	0.063	75
SU200-4T-45G/55P	125	0.1	125	0.056	95
SU200-4T-55G/75P	150	0.09	150	0.046	110
SU200-4T-75G/90P	200	0.07	200	0.035	160
SU200-4T-90G/110P	250	0.06	250	0.028	180
SU200-4T-110G/132P	275	0.05	275	0.025	200
SU200-4T-132G/160P	330	0.04	330	0.02	300
SU200-4T-160G/185P	450	0.03	450	0.017	350
SU200-4T-200G/220P	500	0.028	500	0.015	450
SU200-4T-220G/250P	540	0.026	540	0.013	500
SU200-4T-280G/315P	700	0.02	700	0.01	600

3.5 Installation and wiring

3.5.1 Diagram of single phase 220V input main circuit loop connection

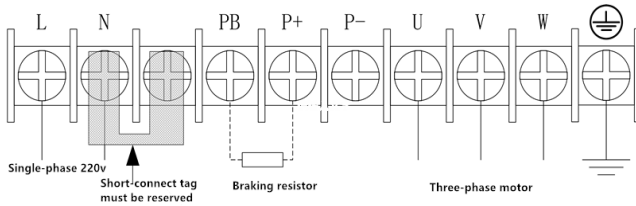

3.5.2 Diagram 3 phase 380V main circuit loop connection for below 22kw drive.

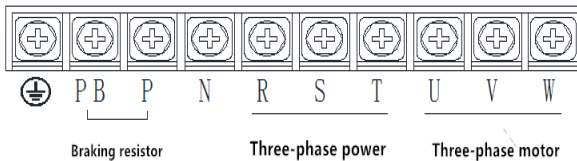

3.5.3 Diagram 3 phase 380V main circuit loop connection for above 30kw inverter.

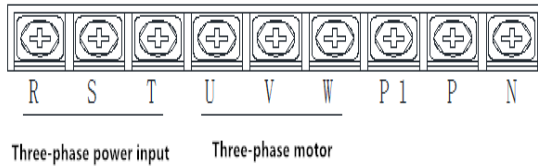

3.6 Main circuit terminals description

Terminals symbol	Function description
L, N	Single phase AC 220V input terminals
R,S,T	3 phase AC 380V input terminals or 3 phase input terminals
U, V, W	Power output terminals for 3 phase AC motor connection
P, N	DC bus terminals of positive and negative and connect with brake unit
P, PB	Braking resistor connection terminals
P1, P	DC chock connecting terminals
⊕	Grounding terminals

3.7 SU200 inverter diagram and terminals

Inverter Diagram :

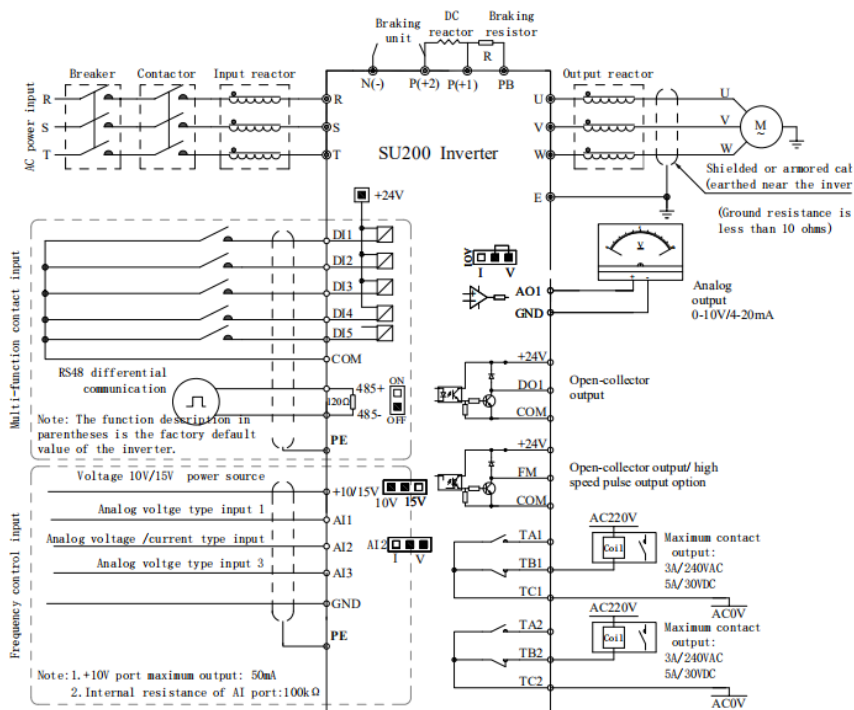

Jumper description

Jumper	Description of Jumper	Default setting
485	485 communication resistor place ON others place OFF	“OFF”position
10V	10v or 15V voltage output	“10V”position
AI2	I for 4 to 20mA current input or V ro 0 to 10V input	“V” for voltage
AO1	I for 4 to 20mA current input or V ro 0 to 10V input	“V” for voltage

DI1 ~ DI5 are compatible with PNP and NPN , DI5 can be use for high speed train pulse input. It can use internet power source 24V or use external 24V power source with jumper to PNP, external power source is ground with COM.

3.7.1 Control circuit terminals and description

3.7.1.1 Control circuit terminals

485A	+10V	AI1	AI2	DI1	DI2	DI3	DI4	DI5				T1/A	T1/B	T1/C	
	485B	GND	AO1	AI3	GND	24V	COM	DO1	FM				T2/A	T2/B	T2/C







3.7.1.2 Control circuit terminals function description

3.7.2 Signal input terminal wiring instruction

Type	symbol	Name of terminals	Specification and explanation
Communication	485A	485+	RS485 communication port , compatible with Modbus
	485B	485-	
Digital input and output	DI1 ~ DI4	Digital input	Sink or source input option set by jumper, input resistance is 2.5K, Optocoupler isolation input, jumper J9
	DI5	Digital input or high speed pulse trains input terminals	General digital input terminal characteristics Pulse trains input maximum frequency: 100KHz
	DO1	Digital output 1	Open collector output Maximum drive capability is 50mA
	FM	Digital output 2	Open collector output, maximum drive capability is 50mA, Can be selected as a pulse trains output, up to 100KHz
Analog input and output	AI1	Analog input 1	Input voltage range: 0V ~ 10V Input resistance: 22K
	AI2	Analog input 2	Input voltage range: 0 ~ 10V or 4 ~ 20mA Input resistance: 22K, jumper J8
	AI3	Analog input 3	Input voltage range: 0 ~ 10V or 4 ~ 20mA Input resistance:22
	AO1	Analog output 1	Output range: 0 ~ 10V or 0 ~ 20mA,select by jumper J5
power supply Reference ground	10V	Analog power supply	Output current: 20mA; Accuracy: 2%
	GND	Analog Ground	Analog reference ground
	24V	User power supply	Accuracy : ±15%
	COM	Digital ground	Digital reference ground
Status relay output	T1/A , T1/B, T1/C	Relay 1	TA/TB normal close、 TA/TC normal open ; Driving capability: 25VAc , 3A , COSØ=0.4 ; 30Vdc , 1A
	T2/A , T2/B, T2/C	Relay 2	TA/TB normal close、 TA/TC normal open ; Driving capability: 25VAc , 3A , COSØ=0.4 ; 30Vdc , 1A

Chapter 4 Operation control panel description

4.1 Press function key description

Key symbol	Name	Function description
	Menu key	Enter menu or return from last step
	Confirm key	Enter to menu step by step or confirm the setting value
	UP increase key	Data and function code increase
	Down decrease key	Data and function code reduce
	SHIFT	In the monitor status, press this key can select display monitoring parameter in circulation. Current output frequency, Current output voltage, Current output current, DC bus voltage value, DC bus current, Input power
	Running key	Us to run motor in keyboard control mode
	Multiple function key	The function of MF.K can be set P7.01 setting. Default setting is no function to program
STOP RESET	Stop and reset	In running status, this key can use to stop motor running (P0-02). Reset malfunction in alarm mode.

4.2. Working status indicating

4.3. Digital display area

5 digit LED display, it can use to display frequency reference, output frequency and kinds of monitoring data and fault alarm code.

4.4. Function code operation

There are 3 level menu in respectively.

1. Function code parameters (First level menu)
2. Function code name (The second level menu)
3. Setting value of function code (the third level menu)

Note: If in the third level menu, you can press PRG or ENTER key to return second menu. The difference is that press ENTER key will keep setting parameter in CPU board of inverter and then return to second menu, press PRG key an return second menu directly without

Symbol	Indicator description
Hz	Unit of frequency (Hz)
A	Unit of current (Amp)
V	Unit of voltage (V)
RUN	Forward run indicator
DIR	Inverter runs in terminal control mode, when P0-02=1 setting
LOCAL	Inverter runs in keyboard control mode, when P0-02=0 setting
TRIP	Fault indicator, inverter will be trip when any alarm happens

parameters store.

Example of keypad operation

1. Modify command source for terminals control

Modify command source for terminals control, the pump will be start once X1 and GND switch ON. If X1 and GND keep turn on status, the inverter will start automatically at morning and turn off automatically at evening if used as solar pump inverter.

2. Modify motor rated power in P1-01. If your rated power of inverter is much bigger than rated motor, please set P1-01 per motor nameplate for better motor protection.

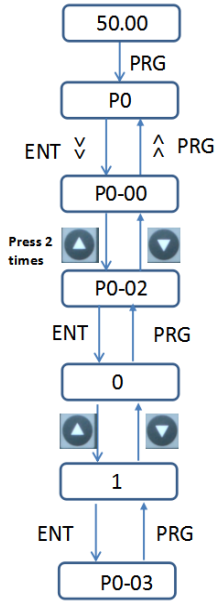

Set P0-02=1 guiding

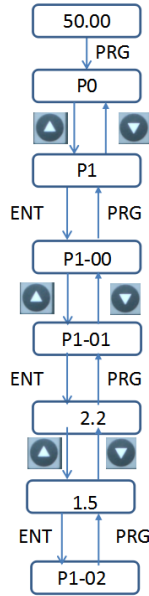

Set P1-02=1.5 kw guiding

4.5. Monitor parameters inquiry.

There two ways to inquiry monitoring parameters.

Press “” to inquiry inverter working status parameters such as output frequency, output current, output voltage, DC voltage and so on.

User also can go to U group parameters to inquiry relative parameters.

Example: Press PRG to return monitoring display window and find to U group, user can get running frequency with U0-00, DC bus voltage from U0-02...

4.6. Fault reset

Solar pump inverter will display relative fault information if there are any alarm occurs.

User can reset it by “STOP/RESET” or external terminals (P402=9, fault reset by DI3 terminals turn on). Once reset, drive place on standby status.

If inverter place in fault reset and without any reset, it located in protection status and can't working.

Chapter 5 Quality Guarantee

5.1 Guarantee time and range

Guarantee time

We will provide 18 month warranty (starting from the leave-factory date as indicated on the barcode) for the failure or damage under normal use conditions. If the equipment has been used for over 18 months, reasonable repair expenses will be charged.

Guarantee range

Installation and debug: In principle, it should be carried by users. Our company gives technic support. But we can afford installation and debugging service with charge.

On-site diagnose: In principle, it should be carried by users. Our company gives technic support. But we can afford on-site diagnosis service with charge. If it is our liability with diagnosis, it will be free of charge.

Malfunction maintaining: While meeting malfunction, if it is quality problem and within guarantee time, we will repair free of charge. The malfunctions, caused by the reasons mentioned as below, can only enjoy the paid service even if the product under warranty:

- The malfunctions caused by improper storage or misoperation which are not in compliance with this user manual.
- The malfunctions caused by unauthorized transform.
- The malfunctions caused by over-range operation.
- Have over guarantee time.
- The malfunctions caused by nature causes.

5.2 Liability exemption

Our company only takes on the liability according to our guarantee time and range. If the user needs more liability guarantee, the user should buy proper commercial insurance from insurance company in advance. The extended loss caused by malfunctions of our product is not within our guarantee range. Cases as following, whether it is within guarantee time or not, are not within our guarantee range. If the user needs service, he has to pay for it.

- The malfunctions caused by improper storage or misoperation which are not in compliance with this user manual.
- The malfunctions caused by unauthorized transform.
- The malfunctions caused by over-range operation.
- Have over guarantee time.
- The malfunctions caused by nature causes.
- User has not paid off the payment according to the contract.

5.3 Product application

- This product is not designed and produced for instruments which are used in cases of vital importance.
- If need to apply this product in manned mobile machine, medical, aerospace, unclear energy, electric power, devices or system for submarine communications transit, please contact the sales department of our company. We do not take on the liability of the accident while this product is used in these cases without authorization.
- This product is produced under strict quality management. But we can not ensure that there will be no malfunction. If the user requires more on safety and reliability, stable device should be deployed. If the user need more guarantee, proper commercial insurance should be considered.

Chapter 6 Function Code Table

The symbols in the function code table are described as follows:

"√": The parameter can be modified when the Inverter is in either stop or running state.

"×": The parameter cannot be modified when the Inverter is in the running state.

"●": The parameter is the actually measured value and cannot be modified.

"*": The parameter is factory parameter and can be set only by the manufacturer.

Function code	Name	Setting range	Factory setting	Modification
P0 Basic function parameters				
P0-00	G/P model display	1: G type (Heavy duty) 2: P type (Pumps/Fans load duty)	Per model	●
P0-01	The first motor control mode	0:VF control 1:Sensorless vector control without PG card feedback 2: Sensor vector control with PG card feedback 3: 2 wires output for 1 phase pump 4: 3 wires output for 1 phase pump (if remove starting capacitor and running capacitor, please select 4. If only remove starting capacitor or difficult to remove starting and running capacitors. Please select 3)	0	×
P0-02	Command mode	0: Keypad (LED OFF) 1:Terminal command (LED ON) 2: RS485 communication (LED flash)	0	√
P0-03	Main frequency reference source X	0: Set by P0-08 of keypad, UP/DOWN setting not saved after power down. 1: Set by P0-08 of keypad, UP/DOWN setting memorized power down. 2: Analog AI1 3: Analog AI2 4: Keypad potentiometer 5: PULSE trains frequency reference (DI5) 6: Multiple step command reference 7: Simple PLC 8. PID 9: RS485 communication	0	×
P0-04	Auxiliary frequency reference source Y	As same as P0-03 (main frequency reference source X)	0	×
P0-05	The auxiliary frequency source Y range basic	0:Relative to the maximum frequency 1:Relative to frequency source X	0	√

SUMO SU200 High Performance Frequency Inverter

Function code	Name	Setting range	Factory setting	Modification
	reference when superposition			
P0-06	The auxiliary frequency source Y range when superposition	0% ~ 150%	100%	√
P0-07	Frequency source selection when superposition	Unit's digit : frequency source selection 0: main frequency source 1:Arithmetic result of main and auxiliary operation (arithmetic relationship operation depends on ten's digit) 2:Switchover between main frequency X source and auxiliary source Y 3: Switchover between main source X and arithmetic operation between of main source X and auxiliary source Y. 4.Switchover between auxiliary source Y and arithmetic operation between of main source X and auxiliary source Y Ten's digit : The arithmetic operation relationship between main and auxiliary. 0: main + auxiliary 1: main – auxiliary 2: Maximum of X and Y 3: Minimum of X and Y	00	√
P0-08	Preset frequency	0.00Hz ~ Maximum (P0-10)	50.00Hz	√
P0-09	Running direction	0: the same direction 1: the opposite direction	0	√
P0-10	Maximum frequency	50.00 Hz ~ 320.00Hz	50.00Hz	×
P0-11	Upper limit frequency source	0: P0-12 parameter 1: AI1 2: AI2 3: potentiometer of keypad 4: PULSE trains 5: Rs485 communication	4	×
P0-12	Upper limit frequency source	Lower limit frequency P0-14 ~ Maximum frequency P0-10	50.00Hz	√
P0-13	Upper limit frequency offset	0.00Hz ~ Maximum frequency P0-10	0.00Hz	√
P0-14	Lower limit frequency	0.00Hz ~ Maximum frequency P0-12	0.00Hz	√
P0-15	Carrier frequency	0.5kHz ~ 16.0kHz	Per	√

SUMO SU200 High Performance Frequency Inverter

Function code	Name	Setting range	Factory setting	Modification
			model	
P0-16	Carrier frequency auto adjusting with temperature	0: Not 1: Yes	1	√
P0-17	Acceleration time 1	0.00s ~ 650.00s(P0-19=2) 0.0s ~ 6500.0s(P0-19=1) 0s ~ 65000s(P0-19=0)	Per model	√
P0-18	Deceleration time 1	0.00s ~ 650.00s(P0-19=2) 0.0s ~ 6500.0s(P0-19=1) 0s ~ 65000s(P0-19=0)	Per model	√
P0-19	Unit of acceleration /deceleration time	0 : 1s 1 : 0.1s 2 : 0.01s	1	×
P0-20	The balance factory for 1 phase pump driving (3 phase output)	0.00 ~ 2.00	1.0	×
P0-21	The offset of auxiliary frequency source when perform Superposition	0.00Hz ~ Maximum frequency F0-10	0.00Hz	√
P0-22	Frequency resolution	1: 0.1Hz 2: 0.01Hz	2	×
P0-23	Memory selection when frequency reference is set by digital	0 : Not save 1 : save	0	√
P0-24	Motor parameter group	0: Motor parameters group 1 1: Motor parameters group 2	0	×
P0-25	The reference frequency of Acceleration/ deceleration time	0: Maximum frequency (P0-10) 1: setting frequency 2: 100Hz	0	×
P0-26	UP/DOWN of reference	0: Running frequency 1: Set frequency	0	×
P0-27	Frequency source and command binding	Unit digit: Frequency source is bound by keypad command 0: No bonding 1: frequency is set by digital 2: AI1 3: AI2 4: Potentiometer of keypad 5: PULSE train (DI5) 6: Multi-step frequency 7: Simple PLC	0000	√

SUMO SU200 High Performance Frequency Inverter

Function code	Name	Setting range	Factory setting	Modification
		8: PID 9: Communication Ten digit: Frequency source is bound by terminals Hundreds digit: Frequency source is bound by communication Thousands of digit: Automatic run Binding frequency source selection		
P1 First motor parameters group				
P1-00	Motor type	0:General asynchronous motor 1: Variable frequency asynchronous motor 3. Permanent magnet synchronous motor	0	×
P1-01	Rated power of motor	0.1KW ~ 1000.0KW	Per model	×
P1-02	Rated voltage of motor	1V ~ 2000V	Per model	×
P1-03	Rated current of motor	Inverter power <= 55KW : 0.01A ~ 655.35A Inverter power > 55KW : 0.1A ~ 6553.5A	Per model	×
P1-04	Rated frequency of motor	0.01Hz ~ Maximum frequency	Per model	×
P1-05	Rated speed of motor	1rpm ~ 65535rpm	Per model	×
P1-06	Asyn. Motor Stator resistance	Inverter power <= 55KW : 0.001Ω ~ 65.535Ω Inverter power > 55KW: 0.0001Ω ~ 6.5535Ω	Auto tuning	×
P1-07	Asyn. motor rotor resistance	Inverter power <= 55KW : 0.001Ω ~ 65.535Ω Inverter power > 55KW : 0.0001Ω ~ 6.5535Ω	Auto tuning	×
P1-08	Asyn. motor Motor leakage inductance	Inverter power <= 55KW : 0.01mH ~ 655.35mH Inverter power > 55KW : 0.001mH ~ 65.535mH	Auto tuning	×
P1-09	Asyn. motor mutual inductance	Inverter power <= 55KW : 0.1mH ~ 6553.5mH Inverter power > 55KW : 0.01mH ~ 655.35mH	Auto tuning	×

SUMO SU200 High Performance Frequency Inverter

Function code	Name	Setting range	Factory setting	Modification
P1-10	Asyn. otor no-load current	Inverter power <= 55KW: 0.01A ~ F1-03 Inverter power > 55KW : 0.1A ~ F1-03	Auto tuning	×
P1-16	Synchronous motor stator resistance	Inverter power <= 55KW : 0.001Ω ~ 65.535Ω Inverter power > 55KW : 0.0001Ω ~ 6.5535Ω	Auto tuning	×
P1-17	Synchronous motor D-axis inductance	Inverter power <= 55KW 0.01mH ~ 655.35mH Inverter power > 55KW : 0.001mH ~ 65.535mH	Auto tuning	×
P1-18	Synchronous motor Q axis inductance	Inverter power <= 55KW : 0.01mH ~ 655.35mH Inverter power > 55KW : 0.001mH ~ 65.535mH	Auto tuning	×
P1-20	Synchronous motor back electromotive force	0.1V ~ 6553.5V	Auto tuning	×
P-21	Identify for synchronous motor parameters	0x0000=0xFFFF	Per modles	
P1-27	Number of encoder lines	1 ~ 65535	1024	×
P1-28	Encoder type	0: ABZ incremental encoder 1: UVW incremental encode 2: Rotary transformer 3: Sine and cosine encoders 4: Provincial line UVW encoder	0	×
P1-30	ABZ incremental encoder phase sequence	0: Forward 1: Reverse	0	×
P1-31	Encoder installation angle	0.0 ~ 359.9°	0.0°	×
P1-32	Reserve	0	0	×
P1-33	Reserve	0	0	×
P1-34	Number of pole pairs of rotary transformers	1 ~ 65535	1	×
P1-36	Speed feedback PG disconnection Detection time	0.0 : on operation 0.1s ~ 10.0s	0.0	×
P1-37	Auto tuning mode selection	0: no operation 1: Asynchronous motor still tunes	0	×

SUMO SU200 High Performance Frequency Inverter

Function code	Name	Setting range	Factory setting	Modification
		2: Asynchronous motor complete tuning 11: Synchronous motor tuning with load 12: Synchronous motor with no-load tuning		
P2 group The first motor vector control parameters				
P2-00	Speed loop proportional gain 1	1 ~ 100	30	√
P2-01	Speed loop integral time 1	0.01s ~ 10.00s	0.50s	√
P2-02	Switching frequency 1	0.00 ~ P2-05	5.00Hz	√
P2-03	Speed loop proportional gain 2	1 ~ 100	20	√
P2-04	Speed loop integral time 2	0.01s ~ 10.00s	1.00s	√
P2-05	Switching frequency 2	P2-02 ~ Maximum frequency	10.00Hz	√
P2-06	Slip compensation coefficient	50% ~ 200%	100%	√
P2-07	Speed loop filter time constant	0.000s ~ 0.100s	0.000s	√
P2-08	Vector control over excitation gain	0 ~ 200	64	√
P2-09	Upper limit of torque source selection in speed control mode	0: Set by P2-10 1: AI1 2: AI2 3: Potentiometer of keypad 4: PULSE train 5: Communication 6: MIN(AI1,AI2) 7: MAX(AI1,AI2) The full range of 1-7 option is correspond to P2-10	0	√
P2-10	Upper limit of torque digital setting in speed control mode	0.0% ~ 200.0%	150.0%	√
P2-13	Excitation adjustment proportional gain	0 ~ 60000	2000	√
P2-14	Excitation adjustment integral gain	0 ~ 60000	1000	√
P2-15	Torque adjustment proportional gain	0 ~ 60000	1000	√
P2-16	Torque adjust integral gain	0 ~ 60000	1000	√

SUMO SU200 High Performance Frequency Inverter

Function code	Name	Setting range	Factory setting	Modification
P2-17	Viewer gain	0.1% -999.9%	100%	√
P2-18	Viewer filter time	0.1%-999.9%	4.0ms	√
P3 group V/F control parameters				
P3-00	V/F curve setting	0: linver V/F 1: multiple points V/F 2: Square V/F 3: 1.2 root square V/F 4: 1.4 root square V/F 6: 1.6 root square V/F 8: 1.8 root square V/F 9: Reserve 10: VF separated totally 11: VF half separated	0	X
P3-01	Torque boost	0.0 % (auto) 1: 1% to 30%	Per models	√
P3-02	Torque boost cut-off frequency	0.00Hz ~ Maximum frequency	50.00Hz	×
P3-03	Multipoint VF frequency point 1	0.00Hz ~ P3-05	0.00Hz	×
P3-04	Multipoint VF voltage point 1	0.0% ~ 100.0%	0.0%	×
P3-05	Multipoint VF frequency point 2	P3-03 ~ P3-07	0.00Hz	×
P3-06	Multipoint VF voltage point 2	0.0% ~ 100.0%	0.0%	×
P3-07	Multipoint VF frequency point 3	P3-05 ~ Motor rated frequency(F1-04)	0.00Hz	×
P3-08	Multipoint VF voltage point 3	0.0% ~ 100.0%	0.0%	×
P3-09	VF Slip compensation gain coefficient	0.0% ~ 200.0%	100.0%	√
P3-10	VF over excitation gain	0 ~ 200	100	√
P3-11	VF oscillation suppression gain	0 ~ 100	50	√
P3-13	VF separate voltage source	0: Set by digital (F3-14) 1: AI1 2: AI2 3: Potentiometer of keypad 4: PULSE train (DI5) 5: Multiple speed command	0	√

SUMO SU200 High Performance Frequency Inverter

Function code	Name	Setting range	Factory setting	Modification
		6: Simple PLC 7: PID 8: Communication Note: 100.0% corresponds to the motor rated voltage		
P3-14	VF separate voltage digital setting	0V ~ Rated motor voltage	0V	√
P3-15	Acceleration time of VF separate	0.0s ~ 1000.0s Note: Indicates the deceleration time when 0V changes to the motor rated voltage	0.0s	√
P4 group Input terminals				
P4-00	DI1 terminals function selection	0:No operation 1: Forward running or running command 2:Reverse running REV 3: 3 line control mode 4: Forward Jog (FJOG) 5: Reverse Jog (RJOG) 6: Terminal UP 7: Terminal DOWN 8: Free stop 9: Fault reset (RESET) 10: Run pause 11: External fault normal open input 12: Multiple step terminals 1 13: Multiple step terminals 2 14: Multiple step terminals 3 15: Multiple step terminals 4 16: Acceleration/ deceleration selection terminals 1 17: Acceleration/ deceleration selection terminals 2 18: Frequency source switch 19: UP/DOWN setting reset (terminals or keypad) 20: Running command terminals switch 21: Acceleration/deceleration forbidden 22: PID pause 23: PLC status reset 24: Swing frequency pause 25: Counter input 26: Counter reset 27: length counting input 28: length reset 29: Torque control forbidden 30: PULSE train frequency input	1	×

SUMO SU200 High Performance Frequency Inverter

Function code	Name	Setting range	Factory setting	Modification
		(only for DI5 valid) 31: Reserve 32: Starting DC braking 33: External fault normal close input 34: Frequency change enable 35: Change PID direction 36: External parking terminal 1 37: Control commands switchover terminal 2 38: PID integral pause 39: Switchover between frequency source X and preset frequency 40: Switchover between frequency source Y and preset frequency 41: Motor selection terminals 1 42: Motor selection terminals 2 43: PID parameter switchover 44: User define fault 1 45: User define fault 2 46: Speed control /Torque control switchover 47: Emergency stop 48: External parking terminal 2 49: DC braking in deceleration 50: current running time reset 51: Water tank fulling detect 1 52: Water tank fulling detect 2 (Install a height place aside from water fulling leveling to form a water fulling detection hysteresis.) 53: MPPT tracking stop/ solar pump control disable. 54-59:Reserved		
P4-01	DI2 terminals function selection		4	×
P4-02	DI3 terminals function selection		9	×
P4-03	DI4 terminals function selection		12	×
P4-04	DI5 terminals function selection		13	×
P4-05	Reserve		0	×
P4-06	Reserve		0	×
P4-07	Reserve		0	×
P4-08	Reserve		0	×
P4-09	Reserve		0	×
P4-10	DI filter time	0.000s ~ 1.000s	0.010s	√
P4-11	Terminals command mode	0: Two line control 1 1: Two line control 2	0	×

SUMO SU200 High Performance Frequency Inverter

Function code	Name	Setting range	Factory setting	Modification
		2: 3 line control 1 3: 3 line control 2		
P4-12	Terminals UP/DOWN Change ratio	0.001Hz/s ~ 65.535Hz/s	1.00Hz/s	√
P4-13	AI curve 1 minimum input	0.00V ~ P4-15	0.00V	√
P4-14	AI curve 1 minimum input corresponding setting	-100.0% ~ +100.0%	0.0%	√
P4-15	AI curve 1 Max. input	P4-13 ~ +10.00V	10.00V	√
P4-16	AI curve 1 Max input corresponding setting	-100.0% ~ +100.0%	100.0%	√
P4-17	AI1 filter time	0.00s ~ 10.00s	0.10s	√
P4-18	AI curve 2 minimum input	0.00V ~ P4-20	0.00V	√
P4-19	AI curve 2 minimum input corresponding setting	-100.0% ~ +100.0%	0.0%	√
P4-20	AI curve 2 Max. input	P4-18 ~ +10.00V	10.00V	√
P4-21	AI curve 2 Max input corresponding setting	-100.0% ~ +100.0%	100.0%	√
P4-22	AI2 filter time	0.00s ~ 10.00s	0.10s	√
P4-23	AI curve 3 minimum input	-10.00V ~ P4-25	-10.00V	√
P4-24	AI curve 3 minimum input corresponding setting	-100.0% ~ +100.0%	-100.0%	√
P4-25	AI curve 3 Max. input	P4-23 ~ +10.00V	10.00V	√
P4-26	AI curve 3 Max input corresponding setting	-100.0% ~ +100.0%	100.0%	√
P4-27	AI3 filter time	0.00s ~ 10.00s	0.10s	√
P4-28	PULSE Min. input	0.00kHz ~ P4-30	0.00kHz	√
P4-29	PULSE Min. input corresponding setting	-100.0% ~ 100.0%	0.0%	√
P4-30	PULSE Maximum input	P4-28 ~ 100.00kHz	50.00kHz	√
P4-31	PULSE Max. Input corresponding setting	-100.0% ~ 100.0%	100.0%	√
P4-32	PULSE filter time	0.00s ~ 10.00s	0.10s	√
P4-33	AI Curve selection	Units' digit : AI1 curve selection 1: Curve 1 (2 point, see P4-13 ~ P4-16) 2: Curve 2 (2 point, see P4-18 ~	321	√

Function code	Name	Setting range	Factory setting	Modification
		P4-21) 3: Curve 3 (2 point, see P4-23 ~ F4-26) 4: Curve 4 (4 point, see A6-00 ~ A6-07) 5: Curve 5 (4 point, see A6-08 ~ A6-15) Ten's digit : AI2 curve selection , as above Hundred's digit: Curve set by potentiometer of keypad, as above		
P4-34	When AI input is less than minimum setting selection	Units' digit: AI 1 is less than minimum input Set selection 0: Corresponds to the minimum input setting 1:0.0% Ten's digit: A2 is less than minimum input Set selection, as above Hundred's digit: Potentiometer less than Min. Input selection, as above	000	√
P4-35	DI1 Relay time	0.0s ~ 3600.0s	0.0s	×
P4-36	DI2 Relay time	0.0s ~ 3600.0s	0.0s	×
P4-37	DI3 Relay time	0.0s ~ 3600.0s	0.0s	×
P4-38	DI terminal effective mode choose 1	0: Enable in High level 1: Enable in low level Digits: DI1 Ten's: DI2 Hundred's: DI3 Thousand's: DI4 Ten thousand's: DI5	00000	×
P4-39	DI terminal effective mode choose 2	0: Enable in High level 1: Enable in low level Digits: DI6 Ten's: DI7 Hundred's: DI8 Thousand's: DI9 Ten thousand's: DI10	00000	×
P5 Group Output terminals				
P5-00	FM terminals output mode selection	0: High speed pulse output (FMP) 1: Digital output (FMR)	0	√
P5-01	FMR output function selection	0: No output 1: Frequency inverter running 2: Fault output (Free stop fault) 3: FDT1 Frequency level detect	0	√

SUMO SU200 High Performance Frequency Inverter

Function code	Name	Setting range	Factory setting	Modification
		output 4: Frequency reach 5: Zero speed running (no output when stop) 6: Motor overload pre-alarm 7: Inverter overload pre-alarm 8: Preset counting reach 9: Specify counting reach 10: Length reach 11: PLC cycle running finish 12: Cumulative run time arrives 13: Frequency limit 14: Torque limit 15: Ready to run 16: AI1>AI2 17: Upper limit frequency arrives 18: Lower limit frequency arrives (relative to running) 17: Upper limit frequency arrives 18: Lower limit frequency arrives 19: Under voltage status output 20: Communication setting 21: Positioning finish (reserve) 22: Positioning approach (Reserve) 23: Zero speed running 2(output when in stop as well) 24: Accumulated power up time arrives 25: Frequency level detection FDT2 output 26: Output when frequency 1 reaches 27: Output when frequency 2 reaches 28: Output when current 1 reaches 29: Output when current 2 reaches 30: Output when timing up 31: AI1 input over limit 32: Under loading 33: reverse running 34: Zero current state 35: Module temperature arrives 36: Output current is exceeded 37: Lower frequency arrival (output when stop as well) 38: Alarm output (all faults) 39: Motor over temperature warning 40: Current running time arrives 41: Fault output (for free stop failure and under voltage is not output)		
P5-02	Relay 1 function selection		2	√
P5-03	Relay 2 function		0	√

SUMO SU200 High Performance Frequency Inverter

Function code	Name	Setting range	Factory setting	Modification
	selection			
P5-04	DO1 output function selection		1	√
P5-05	Extension card DO2 Output selection		4	√o
P5-06	FMP output function selection	0: Running frequency 1: Setting frequency 2: Output current 3: Output torque (Absolute value of torque) 4: Output power 5: Output voltage 6: Pulse input (100% corresponds to 100.0Hz) 7: AI1 8: AI2 9: Keyboard potentiometer 10: Length 11: Count value 12: Communication settings 13: Motor speed 14: Output current (100.0% corresponds to 1000.0A) 15: Output voltage (100.0% corresponds to 1000.0V) 16: Output torque (torque actual value)	0	√
P5-07	AO1 output function selection		0	√
P5-08	AO2 output function selection		1	√
P5-09	FMP maximum frequency	0.01kHz ~ 100.00kHz	50.00k Hz	√
P5-10	AO1 zero bias coefficient	-100.0% ~ +100.0%	0.0%	√
P5-11	AO1 gain	-10.00 ~ +10.00	1.00	√
P5-12	AO2 zero bias	-100.0% ~ +100.0%	0.0%	√
P5-13	AO2 gain	-10.00 ~ +10.00	1.00	√
P5-17	FMR output relay time	0.0s ~ 3600.0s	0.0s	√
P5-18	RELAY1 output relay time	0.0s ~ 3600.0s	0.0s	√
P5-19	RELAY2 output relay time	0.0s ~ 3600.0s	0.0s	√
P5-20	DO1 output relay time	0.0s ~ 3600.0s	0.0s	√
P5-21	DO2 output relay time	0.0s ~ 3600.0s	0.0s	√
P5-22	DO output terminal valid state selection	0: Positive logic 1: Negative logic Bits: FMR	00000	√

SUMO SU200 High Performance Frequency Inverter

Function code	Name	Setting range	Factory setting	Modification
		Ten's bit: RELAY1 Hundreds's bits: RELAY2 Thousands's bits: DO1 Ten thousands's bits: DO2		
P6 Group start and stop control				
P6-00	Starting mode	0: Directly start 1: start after speed tracking 2: Pre-excitation start (AC asynchronous machine)-	0	√
P6-01	Speed tracking mode	00: starts from stop frequency 1: starts at zero speed 2: Starting from the maximum frequency	0	×
P6-02	The speed of speed tracking	1 ~ 100	20	√
P6-03	Starting speed	0.00Hz ~ 10.00Hz	0.00Hz	√
P6-04	Starting speed keeping time	0.0s ~ 100.0s	0.0s	×
P6-05	Start DC braking current / pre-excitation current	0% ~ 100%	0%	×
P6-06	Start DC braking time / pre-excitation time	0.0s ~ 100.0s	0.0s	×
P6-07	Acceleration and deceleration mode	0: Linear acceleration / deceleration 1: S curve acceleration / deceleration A 2: S curve acceleration and deceleration B	0	×
P6-08	S curve starting section time ratio	0.0% ~ (100.0%-P6-09)	30.0%	×
P6-09	S curve finishing section time ratio	0.0% ~ (100.0%-P6-08)	30.0%	×
P6-10	Stop mode	0: Deceleration stop 1: free parking	0	√
P6-11	start frequency when in stop with DC braking	0.00Hz ~ Maximum frequency	0.00Hz	√
P6-12	Waiting time of stop with DC braking	0.0s ~ 100.0s	0.0s	√
P6-13	Braking current when Stop with DC braking	0% ~ 100%	0%	√
P6-14	DC braking time when stop	0.0s ~ 100.0s	0.0s	√
P6-15	Brake usage ratio	0% ~ 100%	100%	√
P7 Group keyboard and display				

SUMO SU200 High Performance Frequency Inverter

Function code	Name	Setting range	Factory setting	Modification
P701	MF.K function button option	0: MF.K is invalid 1: Switchover between Operation panel command channel and remote command channel (terminal command channel or communication command channel) 2: Forward and reverse switching 3: Forward Jog 4: Reverse Jog	0	×
P702	STOP/RESET function	0: STOP/RES button enable only in operation panel control mode 1: STOP/RES button enable in any control mode	1	√
P703	LED display parameters 1 in running mode	0000 ~ FFFF Bit00: Running frequency 1(Hz) Bit01: Setting frequency (Hz) Bit02: DC bus voltage (V) Bit03: Output voltage (V) Bit04: Output current (A) Bit05: Output power (KW) Bit06: Output torque (%) Bit07: DI input status Bit08: DO output status Bit09: AI1 voltage (V) Bit10: AI2 voltage (V) Bit11: Voltage of potentiometer(V) Bit12: Counting Bit13: Length Bit14: Load speed display Bit15: PID setting	1F	√
P7-04	LED display parameters 2 in running mode	0000 ~ FFFF Bit00: PID feedback Bit01: PLC stage Bit02: PULSE input pulse train frequency (kHz) Bit03: Running frequency 2 (Hz) Bit04: Rest running time Bit05: AI1 before correction voltage (V) Bit06: AI2 before correction voltage (V) Bit07: operation panel potentiometer before correction voltage (V) Bit08: Line speed Bit09: Current power-on time (Hour) Bit10: Current running time (Min) Bit11: PULSE train input pulse frequency (Hz) Bit12: Communication set point Bit13: Encoder feedback speed	0	√

SUMO SU200 High Performance Frequency Inverter

Function code	Name	Setting range	Factory setting	Modification
		(Hz) Bit14: Main frequency X display (Hz) Bit15: Auxiliary Frequency Y Display (Hz)		
P7-05	LED display in stop mode	0000 ~ FFFF Bit00: Set frequency (Hz) Bit01: Bus voltage (V) Bit02: DI input status Bit03: DO output status Bit04: AI1 voltage (V) Bit05: AI2 voltage (V) Bit06: Operation panel potentiometer voltage (V) Bit07: Count value Bit08: Length value Bit09: PLC stage Bit10: Load speed Bit11: PID setting Bit12: PULSE train input pulse frequency (kHz)	33	√
P7-06	Load speed display factor	0.0001 ~ 6.5000	1.0000	√
P7-07	Heat sink of Inverter IGBT model temperature	0.0°C ~ 100.0°C	-	•
P7-08	Heat sink of Inverter Rectifier temperature	0.0°C ~ 100.0°C	-	•
P7-09	Cumulative run time	0h ~ 65535h	-	•
P7-10	Products serial No.	-	-	•
P7-11	Software version No.	-	-	•
P7-12	The number of decimal places of load speed Displays	0: 0 decimal places 1: 1 decimal place 2: 2 decimal places 3: 3 decimal places	1	√
P7-13	Accumulated time since power on	0 ~ 65535 hour	-	•
P7-14	Cumulative power consumption	0 ~ 65535 KWh	-	•
P8 group Auxiliary function				
P8-01	Jog acceleration	0.0s ~ 6500.0s	20.0s	√
P8-02	Jog deceleration	0.0s ~ 6500.0s	20.0s	√
P8-03	Acceleration time 2	0.0s ~ 6500.0s	Per model	√
P8-04	Deceleration time 2	0.0s ~ 6500.0s	Per model	√

SUMO SU200 High Performance Frequency Inverter

Function code	Name	Setting range	Factory setting	Modification
P8-05	Acceleration time 3	0.0s ~ 6500.0s	Per model	√
P8-06	Deceleration time 3	0.0s ~ 6500.0s	Per model	√
P8-07	Acceleration time 4	0.0s ~ 6500.0s	Per model	√
P8-08	Deceleration time 4	0.0s ~ 6500.0s	Per model	√
P8-09	Jumping frequency 1	0.00Hz ~ Maximum frequency	0.00Hz	√
P8-10	Jumping frequency 2	0.00Hz ~ Maximum frequency	0.00Hz	√
P8-11	Jump frequency range	0.00Hz ~ Maximum frequency	0.01Hz	√
P8-12	Dead zone time of forward to reverse	0.0s ~ 3000.0s	0.0s	√
P8-13	Reverse running enable	0: Allow 1: Forbidden	0	√
P8-14	Running mode when setting frequency is less than the lower limit frequency	0: Run at lower limit frequency 1: stop 2: Zero speed running	0	√
P8-15	Drop control	0.00Hz ~ 10.00Hz	0.00Hz	√
P8-16	Set the cumulative power-up arrival time	0h ~ 65000h	0h	√
P8-17	Set the cumulative running arrival time	0h ~ 65000h	0h	√
P8-18	Start protection selection	0: Disable 1: Enable	0	√
P8-19	Frequency detection value (FDT1)	0.00Hz ~ Maximum frequency	50.00Hz	√
P8-20	Frequency detection hysteresis (FDT1)	0.0% ~ 100.0%(FDT1 voltage level)	5.0%	√
P8-21	Frequency arrival detection amplitude	0.0% ~ 100.0%(Maximum frequency)	0.0%	√
P8-22	Whether the jump frequency is valid during acceleration / deceleration	0: Invalid 1: Valid	0	√
P8-25	Switch over point between acceleration time 1 to acceleration time 2	0.00Hz ~ Maximum frequency	0.00Hz	√
P8-26	Switch over point between deceleration time 1 to deceleration time 2	0.00Hz ~ Maximum frequency	0.00Hz	√

SUMO SU200 High Performance Frequency Inverter

Function code	Name	Setting range	Factory setting	Modification
P8-27	Terminal control prior	0 : Invalid 1: Valid	0	√
P8-28	Frequency detection value (FDT2)	0.00Hz ~ Maximum frequency	50.00Hz	√
P8-29	Frequency detection hysteresis (FDT2)	0.0% ~ 100.0%(FDT2 voltage level)	5.0%	√
P8-30	Any arrival frequency detection value 1	0.00Hz ~ Maximum frequency	50.00Hz	√
P8-31	Any arrival frequency detection amplitude 1	0.0% ~ 100.0%(Maximum frequency)	0.0%	√
P8-32	Any arrival frequency detection value 2	0.00Hz ~ Maximum frequency	50.00Hz	√
P8-33	Any arrival frequency detection amplitude 2	0.0% ~ 100.0%(Maximum frequency)	0.0%	√
P8-34	Zero current detection level	0.0% ~ 300.0% 100.0% corresponds to the motor rated current	5.0%	√
P8-35	Zero current detection delay time	0.01s ~ 600.00s	0.10s	√
P8-36	Output current over limit	0.0%(No detect) 0.1% ~ 300.0%(Rated current)	200.0%	√
P8-37	Output current over limit detect relay time	0.00s ~ 600.00s	0.00s	√
P8-38	Any arrival current 1	0.0% ~ 300.0%(Motor rated current)	100.0%	√
P8-39	Any arrival current 1 detect amplitude	0.0% ~ 300.0% (Motor rated current)	0.0%	√
P8-40	Any arrival current 2	0.0% ~ 300.0% (Motor rated current)	100.0%	√
P8-41	Any arrival current 2 detect amplitude	0.0% ~ 300.0% (Motor rated current)	0.0%	√
P8-42	Timing function selection	0: Invalid 1: Valid	0	√
P8-43	Timing of run time selection	0: Set by P8-44 1: AI1 2: AI2 3: Potentiometer of operation panel The range of analog input corresponds to P8-44	0	√
P8-44	Timing value setting of running time	0.0Min ~ 6500.0Min	0.0Min	√
P8-45	Lower limit of AI1 input voltage protection	0.00V ~ P8-46	3.10V	√
P8-46	Upper limit of AI1 input voltage protection	P8-45 ~ 10.00V	6.80V	√

SUMO SU200 High Performance Frequency Inverter

Function code	Name	Setting range	Factory setting	Modification
P8-47	IGBT Module temperature arrives	0℃ ~ 100℃	75℃	√
P8-48	Cooling fan control	0: Working in running 1: Working after power up	0	√
P8-49	Wake up frequency	Sleep frequency (P8-51) ~ Maximum (P0-10)	0.00Hz	√
P8-50	Wake up delay time	0.0s ~ 6500.0s	0.0s	√
P8-51	Sleep frequency	0.00Hz ~ Wake up frequency (P8-49)	0.00Hz	√
P8-52	Sleep relay time	0.0s ~ 6500.0s	0.0s	√
P8-53	Current running arrival time setting	0.0 ~ 6500.0 mins	0.0Min	√
P9 Group fault and protection				
P9-00	Motor overload protection selection	0: Prohibited 1: Allow	1	√
P9-01	Motor overload protection gain	0.20 ~ 10.00	1.00	√
P9-02	Motor overload pre-warning coefficient	50% ~ 100%	80%	√
P9-03	Overvoltage stall gain	0 ~ 100	100	√
P9-04	Overvoltage stall protection voltage	120% ~ 150%	135%	√
P9-05	Over-current stall gain	0 ~ 100	20	√
P9-06	Overcurrent stall protection current	100% ~ 200%	150%	√
P9-07	Ground short circuit protection options when power on	0: Invalid 1: Valid	1	√
P9-08	Under voltage setting	0-999%	100%	√
P9-09	Number of automatic reset times	0 ~ 20	0	√
P9-10	DO (digital output) when fault alarm auto reset	0: No action 1: Action	0	√
P9-11	Fault auto reset interval time	0.1s ~ 100.0s	1.0s	√
P9-12	Input phase loss/ contactor pull protection selection	Bit: Input phase loss protection selection Ten: Contactor pull protection options 0: Prohibited 1: Allow	11	√
P9-13	Output phase loss	0: Prohibited	1	√

SUMO SU200 High Performance Frequency Inverter

Function code	Name	Setting range	Factory setting	Modification
	protection	1: Allow		
P9-14	First failure alarm type	0: No fault 1: Reserved 2: Over current in acceleration 3: Over current in deceleration 4: Over current in constant speed during 5: Over voltage in acceleration 6: Over voltage in deceleration 7: Over voltage in constant speed during 8: Buffer resistance overload 9: Under voltage 10: Inverter overload 11: Motor overload 12: Input phase loss	-	•
P9-15	Second fault alarm type	13: Output phase loss 14: IGBT Module overheating 15: External fault 16: Communication error 17: Contactor is abnormal 18: Current detection is abnormal 19: Motor tuning abnormal 20: Encoder / PG card is abnormal 21: Parameter read and write exception 22: Inverter hardware abnormality 23: Motor to ground short circuit 24: Reserved 25: Reserved	-	•
P9-16	The third (latest one) type of failure	26: Running time arrives 27: User defined fault 1 28: user defined fault 2 29: Power-up time arrives 30: Under load 31: PID feedback is missing in running 40: Fast current limit timeout 41: Motor switch in running 42: The speed deviation is too big 43: Motor over speed 45: Motor over temperature 51: Initial position error	-	•
P9-17	Frequency at when the third (last) failure frequency	-	-	•
P9-18	Current at when the third (last) failure frequency	-	-	•
P9-19	DC bus voltage at when	-	-	•

SUMO SU200 High Performance Frequency Inverter

Function code	Name	Setting range	Factory setting	Modification
	the third (last) failure frequency			
P9-20	Input terminals status at when the third (last) failure frequency	-	-	●
P9-21	Output terminals status at when the third (last) failure frequency	-	-	●
P9-22	Inverter status when the third (last) failure frequency	-	-	●
P9-23	Power up time when the third (last) failure frequency	-	-	●
P9-24	Running time when the third (last) failure frequency	-	-	●
P9-27	Frequency at when the second failure	-	-	●
P9-28	Current at when the second failure	-	-	●
P9-29	DC bus voltage at when the second failure	-	-	●
P9-30	Input terminals status at when the second failure	-	-	●
P9-31	Output terminals status at when the second failure	-	-	●
P9-32	Inverter status at when the second failure	-	-	●
P9-33	Power up time when the second failure	-	-	●
P9-34	Running time when the second failure	-	-	●
P9-37	Frequency at when the third failure	-	-	●
P9-38	Current at when the third failure	-	-	●
P9-39	DC bus voltage at when the third failure	-	-	●
P9-40	Input terminals status at when the third failure	-	-	●
P9-41	Output terminals status at when the third failure	-	-	●

SUMO SU200 High Performance Frequency Inverter

Function code	Name	Setting range	Factory setting	Modification
P9-42	Inverter status at when the third failure	-	-	●
P9-43	Power up time when the third failure	-	-	●
P9-44	Running time when the third failure	-	-	●
P9-47	Fault protection action selection 1	Bit: Motor overload (11) 0: Free stop 1: Stop by stop mode setting 2: Continue to run Ten: Input missing (12) Hundreds: Output phase loss (13) Thousands of bits: external failure (15) Million: communication anomaly (16)	00000	√
P9-48	Fault protection action selection 3	Unit's digit: Encoder / PG card exception (20) 0: Free stop Ten' digit: Function code read and write exception (21) 0: Free stop 1: Stop by stop mode setting Hundred's digit: reserved Thousand's digit: Motor overheating (25) Million: run time arrival (26)	00000	√
P9-49	Fault protection action selection 3	Unit's digit: User defined fault 1 (27) 0: Free stop 1: Stop by stop mode 2: Continue to run Ten' digit: User Defined Fault 2 (28) 0: Free Stop 1: Stop by stop mode 2: Continue to run Hundred's digit: Power-up time arrives (29) 0: Free stop 1: Stop by stop mode 2: Continue to run Thousands of bits: (30) 0: Free stop 1: Deceleration stop 2: Skip to 7% of the rated motor frequency to continue running, restore to run with setting frequency after no missing load Million: PID feedback lost in running (31) 0: Free parking 1: Stop by stop mode 2: Continue to run	00000	√

SUMO SU200 High Performance Frequency Inverter

Function code	Name	Setting range	Factory setting	Modification
P9-50	Fault protection action selection 4	Bit: the speed deviation is too large (42) 0: Free stop 1: Stop by stop mode 2: Continue to run Ten: Motor over speed (43) Hundred places: initial position error (51)	00000	√
P9-54	Running frequency of continue running when fault alarm	0: Run at the current operating frequency 1: Run at set frequency 2: Run at the upper limit frequency 3: Run at the lower limit frequency 4: Run at an abnormal standby frequency	0	√
P9-55	An abnormal standby frequency	0.0% ~ 100.0% (100.0% corresponds to the maximum frequency P0-10)	100.0%	√
P9-56	Motor temperature sensor type	0: No temperature sensor 1 : PT100 2 : PT1000	0	√
P9-57	Motor overheat protection threshold	0°C ~ 200°C	110°C	√
P9-58	Motor overheat pre-warning threshold	0°C ~ 200°C	90°C	√
P9-59	Working action of instantaneous power fail selection	0: Invalid 1: Deceleration 2: Deceleration stop	0	√
P9-60	Judgment voltage of instantaneous power fail pause	80.0% ~ 100.0%	90.0%	√
P9-61	Voltage recovery judgment time when instantaneous power fail	0.00s ~ 100.00s	0.50s	√
P9-62	Judgment voltage of instantaneous power failure action	60.0% ~ 100.0%(Standard bus voltage)	80.0%	√
P9-63	Load miss protection	0: Disable 1: Enable	0	√
P9-64	Load miss detection level	0.0 ~ 100.0%	10.0%	√
P9-65	Load miss detection time	0.0 ~ 60.0s	1.0s	√
P9-67	Over speed detection	0.0% ~ 50.0%(Max frequency)	20.0%	√

SUMO SU200 High Performance Frequency Inverter

Function code	Name	Setting range	Factory setting	Modification
P9-68	Over speed detection time	0.0s: No detect 0.1 ~ 60.0s	1.0s	√
P9-69	Detection value of the speed deviation is too big	0.0% ~ 50.0%(Max frequency)	20.0%	√
P9-70	Detection time of speed deviation is too big.	0.0s: No detect 0.1 ~ 60.0s	5.0s	√
PA Group PID function				
PA-00	PID reference source	0: PA-01 1: AI1 2: AI2 3: Keyboard potentiometer 4: PULSE train setting (DI5) 5: Communication reference 6: Multi-step instructions reference	0	√
PA-01	PID value setting	0.0% ~ 100.0%	50.0%	√
PA-02	PID feedback source	0 : AI1 1: AI2 2: Keyboard potentiometer 3: AI1-AI2 4: PULSE setting (DI5) 5: Communication reference 6: AI1 + AI2 7: MAX (AI1 , AI2) 8: MIN (AI1 , AI2)	0	√
PA-03	PID working direction	0: Positive effect 1: Reverse effect	0	√
PA-04	PID reference feedback range	0 ~ 65535	1000	√
PA-05	Proportional gain Kp1	0.0 ~ 100.0	20.0	√
PA-06	Integral time Ti1	0.01s ~ 10.00s	2.00s	√
PA-07	Differential time Td1	0.000s ~ 10.000s	0.000s	√
PA-08	PID reversal cutoff frequency	0.00 ~ Maximum frequency	2.00Hz	√
PA-09	PID deviation limit	0.0% ~ 100.0%	0.0%	√
PA-10	PID differential limiting	0.00% ~ 100.00%	0.10%	√
PA-11	PID reference given change time	0.00 ~ 650.00s	0.00s	√
PA-12	PID feedback filter time	0.00 ~ 60.00s	0.00s	√
PA-13	PID output filter time	0.00 ~ 60.00s	0.00s	√

SUMO SU200 High Performance Frequency Inverter

Function code	Name	Setting range	Factory setting	Modification
PA-14	Reserve	-	-	√
PA-15	Proportional gain Kp2	0.0 ~ 100.0	20.0	√
PA-16	Integral time Ti2	0.01s ~ 10.00s	2.00s	√
PA-17	Derivative time Td2	0.000s ~ 10.000s	0.000s	√
PA-18	PID parameter switching condition	0: Do not switch 1: Switch via DI terminal 2: Automatic switching according to the deviation	0	√
PA-19	PID parameter switching deviation 1	0.0% ~ PA-20	20.0%	√
PA-20	PID parameter switching deviation 2	FA-19 ~ 100.0%	80.0%	√
PA-21	PID initial value	0.0% ~ 100.0%	0.0%	√
PA-22	PID initial value hold time	0.00 ~ 650.00s	0.00s	√
PA-23	The maximum value of positive deviations for two output	0.00% ~ 100.00%	1.00%	√
PA-24	The maximum value of reverse deviations for two output	0.00% ~ 100.00%	1.00%	√
PA-25	PID integral property	Bit: Integral separation 0: Invalid 1: Valid Ten: Whether to stop the integral working after outputting to the limit 0: Continue integral working 1: Stop integral working	00	√
PA-26	PID feedback loss detection value	0.0%:Do not judge feedback loss 0.1% ~ 100.0%	0.0%	√
PA-27	PID Feedback loss detection time	0.0s ~ 20.0s	0.0s	√
PA-28	PID calculating when stop	0 : Don't execute calculating when stop 1: Execute PID calculating when stop	0	√
Pb Group wobble, length and count				
Pb-00	Wobble setting mode	0: Relative to center frequency 1: Relative to maximum frequency	0	√
Pb-01	Wobble amplitude	0.0% ~ 100.0%	0.0%	√
Pb-02	Sudden jump frequency range	0.0% ~ 50.0%	0.0%	√

SUMO SU200 High Performance Frequency Inverter

Function code	Name	Setting range	Factory setting	Modification
Pb-03	Wobble cycle	0.1s ~ 3000.0s	10.0s	√
Pb-04	Wobble of the triangular wave rise time	0.1% ~ 100.0%	50.0%	√
Pb-05	Set length	0m ~ 65535m	1000m	√
Pb-06	Actual length	0m ~ 65535m	0m	√
Pb-07	Number of pulses per meter	0.1 ~ 6553.5	100.0	√
Pb-08	Set the count value	1 ~ 65535	1000	√
Pb-09	Specify the count value	1 ~ 65535	1000	√
PC Group multi-step instructions, simple PLC				
PC-00	Multi - step instructions 0	-100.0% ~ 100.0%	0.0%	√
PC-01	Multi - step instructions 1	-100.0% ~ 100.0%	0.0%	√
PC-02	Multi - step instructions 2	-100.0% ~ 100.0%	0.0%	√
PC-03	Multi - step instructions 3	-100.0% ~ 100.0%	0.0%	√
PC-04	Multi - step instructions 4	-100.0% ~ 100.0%	0.0%	√
PC-05	Multi - step instructions 5	-100.0% ~ 100.0%	0.0%	√
PC-06	Multi - step instructions 6	-100.0% ~ 100.0%	0.0%	√
PC-07	Multi - step instructions 7	-100.0% ~ 100.0%	0.0%	√
PC-08	Multi - step instructions 8	-100.0% ~ 100.0%	0.0%	√
PC-09	Multi - step instructions 9	-100.0% ~ 100.0%	0.0%	√
PC-10	Multi - step instructions 10	-100.0% ~ 100.0%	0.0%	√
PC-11	Multi - step instructions 11	-100.0% ~ 100.0%	0.0%	√
PC-12	Multi - step instructions 12	-100.0% ~ 100.0%	0.0%	√
PC-13	Multi - step instructions 13	-100.0% ~ 100.0%	0.0%	√
PC-14	Multi - step instructions 14	-100.0% ~ 100.0%	0.0%	√

SUMO SU200 High Performance Frequency Inverter

Function code	Name	Setting range	Factory setting	Modification
PC-15	Multi - step instructions 15	-100.0% ~ 100.0%	0.0%	√
PC-16	Simple PLC running mode	0: Single run to end and stop 1: Single run to end and keep final value 2: Continue to run in loop	0	√
PC-17	Simple PLC power loss memory selection	Bit: Power off memory options 0: No memory power-off 1: Power off memory Ten: Stop memory selection 0: Stop no memory 1: Stop memory	00	√
PC-18	Simple PLC 0 step running time	0.0s(h) ~ 6553.5s(h)	0.0s/h	√
PC-19	Acc./Dec. time selection of 0 step of simple PLC	0 ~ 3	0	√
PC-20	Simple PLC 1st step running time	0.0s(h) ~ 6553.5s(h)	0.0s/h	√
PC-21	Acc./Dec. time selection of 1st step of simple PLC	0 ~ 3	0	√
PC-22	Simple PLC 2nd step running time	0.0s(h) ~ 6553.5s(h)	0.0s/h	√
PC-23	Acc./Dec. time selection of 2nd step of simple PLC	0 ~ 3	0	√
PC-24	Simple PLC 3rd step running time	0.0s(h) ~ 6553.5s(h)	0.0s/h	√
PC-25	Acc./Dec. time selection of 3rd step of simple PLC	0 ~ 3	0	√
PC-26	Simple PLC 4th step running time	0.0s(h) ~ 6553.5s(h)	0.0s/h	√
PC-27	Acc./Dec. time selection of 4th step of simple PLC	0 ~ 3	0	√
PC-28	Simple PLC 5th step running time	0.0s(h) ~ 6553.5s(h)	0.0s/h	√
PC-29	Acc./Dec. time selection of 5th step of simple PLC	0 ~ 3	0	√
PC-30	Simple PLC 6th step running time	0.0s(h) ~ 6553.5s(h)	0.0s/h	√
PC-31	Acc./Dec. time selection of 6th step of simple PLC	0 ~ 3	0	√

SUMO SU200 High Performance Frequency Inverter

Function code	Name	Setting range	Factory setting	Modification
PC-32	Simple PLC 7th step running time	0.0s(h) ~ 6553.5s(h)	0.0s/h	√
PC-33	Acc./Dec. time selection of 7th step of simple PLC	0 ~ 3	0	√
PC-34	Simple PLC 8th step running time	0.0s(h) ~ 6553.5s(h)	0.0s(h)	√
PC-35	Acc./Dec. time selection of 8th step of simple PLC	0 ~ 3	0	√
PC-36	Simple PLC 9th step running time	0.0s(h) ~ 6553.5s(h)	0.0s/h	√
PC-37	Acc./Dec. time selection of 9th step of simple PLC	0 ~ 3	0	√
PC-38	Simple PLC 10th step running time	0.0s(h) ~ 6553.5s(h)	0.0s/h	√
PC-39	Acc./Dec. time selection of 10th step of simple PLC	0 ~ 3	0	√
PC-40	Simple PLC 11th step running time	0.0s(h) ~ 6553.5s(h)	0.0s/h	√
PC-41	Acc./Dec. time selection of 11th step of simple PLC	0 ~ 3	0	√
PC-42	Simple PLC 12th step running time	0.0s(h) ~ 6553.5s(h)	0.0s/h	√
PC-43	Acc./Dec. time selection of 12th step of simple PLC	0 ~ 3	0	√
PC-44	Simple PLC 13th step running time	0.0s(h) ~ 6553.5s(h)	0.0s/h	√
PC-45	Acc./Dec. time selection of 13th step of simple PLC	0 ~ 3	0	√
PC-46	Simple PLC 14th step running time	0.0s(h) ~ 6553.5s(h)	0.0s/h	√
PC-47	Acc./Dec. time selection of 14th step of simple PLC	0 ~ 3	0	√
PC-48	Simple PLC 15th step running time	0.0s(h) ~ 6553.5s(h)	0.0s/h	√
PC-49	Acc./Dec. time selection of 15th step of simple PLC	0 ~ 3	0	√

SUMO SU200 High Performance Frequency Inverter

Function code	Name	Setting range	Factory setting	Modification
PC-50	Simple PLC run time unit	0 : s (2) 1 : h (hour)	0	√
PC-51	Multi-step instruction 0 step given mode	0: set by FC-00 1 : AI1 2 : AI2 3: Keyboard potentiometer 4: PULSE train 5: PID 6: Preset frequency (F0-08) is given, UP / DOWN can be modify	0	√
Pd Group communication				
Pd-00	Communication baud rate	bit : MODBUS 0 : 300BPS 1 : 600BPS 2 : 1200BPS 3 : 2400BPS 4 : 4800BPS 5 : 9600BPS 6 : 19200BPS 7 : 38400BPS 8 : 57600BPS 9 : 115200BPS Ten: Profibus-DP 0 : 115200BPs 1 : 208300BPs 2 : 256000BPs 3 : 512000Bps Hundred places: reserved	6005	√
Pd-01	MODBUS data format	0: No parity (8-N-2) 1: Even check (8-E-1) 2: Odd parity (8-O-1) 3: No parity (8-N-1) (MODBUS active)	0	√
Pd-02	Local address	0 : Broadcast address 1 ~ 249 (MODBUS、Profibus-DP、CANlink enable)	1	√
Pd-03	MODBUS respond relay	0 ~ 20ms	2	√

SUMO SU200 High Performance Frequency Inverter

Function code	Name	Setting range	Factory setting	Modification
		(MODBUS enable)		
Pd-04	Serial communication timeout	0.0 : Disable 0.1 ~ 60.0s (MODBUS, Profibus-DP, CANopen enable)	0.0	√
PP Group function code management				
PP-00	User password	0 ~ 65535	0	√
PP-01	Parameter initialization	0: On operation 1: Restore parameters to factory setting except motor parameters 2: Clear record information	0	√
PP-02	Function parameter group display selection	Bit: U group monitoring parameters 0: Not displayed 1: Display Ten: Advanced parameters 0: Not displayed 1: display	01	×
PP-03	Personality parameter group show selection	Bit: User custom parameter group display selection 0: Not displayed 1: Display Ten: User Change Parameter Group Display Selection 0: Not displayed 1: Display	00	√
PP-04	Function code modification attribute	0 : Enable modification 1: Not allow to modify	0	√
PP-05	Distributor unlock password	0 - 65535		
PP-06	Factory unlock password	0 - 65535		
PF Distributor password setting				
PF-06	Distributor password setting	0 - 65535		
PF-07	Distributor allow total running time	0 - 65535Hr	Maximum 7.4 Year	
PE group for solar pump control purpose (solar pump control version)				
PE-00	Solar pump control mode	0:Disable of solar pump control 1: Enable (Algorithm-1, High efficiency) 2: Enable (Algorithm-2, High stability) User can use terminal to disable solar pump control mode, make inverter work <u>as</u> motor variable	2	X

SUMO SU200 High Performance Frequency Inverter

Function code	Name	Setting range	Factory setting	Modification
		speed control. See Digital terminal definition 53: MPPT/Solar control disable. (set P4-02=53, switch on DI3 and COM) Terminal control is prior.		
PE-01	Solar pump control mode option	1 Bit: Vmpp mode selecting 0: Vmp set by PE-02 manually (CVT) 1: MPPT automatically Ten: Voc (open loop voltage of PV) detect mode 0: Voc set by PE-03 manually 1: Voc detect automatically Hundred: Auto running by keypad 0: Disable 1: Auto start/stop in keypad control mode. Inverter will automatically start when power on after 5 seconds <u>only</u> on keypad control mode.	H_001	√
PE-02	CVT voltage set by manual	0 -100%	80%	√
PE-03	Voc (open loop voltage) set manually	0.0V-1000.0V	650V/ 380V	V
PE-04	DC bus voltage stability Proportional gain	0.0% - 999.9%	100.0%	√
PE-05	DC bus voltage stability Integral gain	0.0% - 999.9%	100.0%	√
PE-06	DC bus voltage stability differential gain	0.0% - 999.9%	5%	√
PE-07	Initial point of fast frequency drop	0.0 - 100.0%	5_0%	√
PE-08	Stop point of fast frequency drop	0.0 - 100.0%	50.0%	
PE-09	Weak magnetic limit multiples	0.0- 9.9	1.2	
PE-10	Mppt search upper limit voltage	0.0% - 100.0%	90%	√
PE-11	Mppt search lower limit voltage	0.0% - 100.0%	75%	√
PE-12	MPPT search gain	0% - 500%	100%	√
PE-13	MPPT search interval	0.0 - 10.0sec	2.0sec	√
PE-14	Stabilizer filtering time (solar pump control mode2)	0-1000ms	50ms	<u>√</u>
PE-15	Stabilizer voltage threshold (solar pump control	10.0V – 100.0V	10.0V	<u>√</u>

SUMO SU200 High Performance Frequency Inverter

Function code	Name	Setting range	Factory setting	Modification
	mode2)			
PE-16	Sleep voltage threshold	0.0 $\underline{=}$ 1000.0V	250.0V/ 150.0V	√
PE-17	Wake up voltage threshold	0.0 $\underline{=}$ 1000.0V	350.0V/ 250.0V	√
PE-18	Awake waiting time	0 $\underline{=}$ 30000sec	60sec	√
PE-19	Stop frequency setting when low speed	0.00Hz ~ 300.00Hz	10.00Hz	√
PE-20	Detecting time of low frequency protection	0 $\underline{=}$ 30000sec	20sec	√
PE-21	Low speed protection auto reset delay time	0 $\underline{=}$ 30000sec	60sec	√
PE-22	Dry run protection detecting current	0.0 $\underline{=}$ 999.9A	0.0A	√
PE-23	Dry run protection detecting time	0 $\underline{=}$ 30000sec	10sec	√
PE-24	Dry run protection auto reset relay time	0 $\underline{=}$ 30000sec	60sec	√
PE-25	Detecting current of over current protection	0.0 $\underline{=}$ 999.9A	0.0A	√
PE-26	Detecting time of over current protection	0 $\underline{=}$ 30000sec	10sec	√
PE-27	Over current auto reset delay time	0 $\underline{=}$ 30000sec	60sec	√
PE-28	Minimum power protection value	0.00kw $\underline{=}$ 650.00kw	0.00kw	√
PE-29	Detecting time of minimum power protection	0 $\underline{=}$ 30000sec	10sec	√
PE-30	Minimum power protection auto reset delay time	0 $\underline{=}$ 30000sec	60sec	√
PE-31	Water tank fulling level detecting method	Digit: Water fulling detect mode 0: Single point detect 1: 2 points detect 2: AI1 analog 3: AI2 analog Ten: Single point detect 51# function logic detection selecting Hundred: Single point detect 52# function logic detection selecting. 0: Normal Open, work when open, stop when switch on	H0.0.0	√

SUMO SU200 High Performance Frequency Inverter

Function code	Name	Setting range	Factory setting	Modification
		1: Normal close, work when close, stop when open. <u>Note:Single point detecting,when DI4 set for 51(in default setting),adopt 5sec hysteresis detecting. 2 points detecting,DI4 set for 51,DI5 set for 52, both points should be activated at the same time to make water fulling function useful.</u>		
PE-32	Water fulling level detecting threshold of analogtype.	0 _ 100.0%	25.0%	√
PE-33	Water fulling level reach protection detecting time	0 _ 30000sec	10sec	√
PE-34	Water fulling level protection exit relay time	0 _ 30000sec	10 sec	√
PE-35	Water level sensor probe damage threshold	0 _ 100.0%	0.0%	√
PE-36	DC current correction factor	0.0 _ 200.0%	100.00%	√
PE-37	DC current correction bias	-100.00A _ 100.00A	0.00A	√
PE-38	Power point 0 of PQ Current	0.0kw _ 999.9kw	0.5kw	√
PE-39	Power point 1 of PQ Current	0.0kw _ 999.9kw	1.0kw	√
PE-40	Power point 2 of PQ Current	0.0kw _ 999.9kw	1.5kw	√
PE-41	Power point 3 of PQ Current	0.0kw _ 999.9kw	2.0kw	√
PE-42	Power point 4 of PQ Current	0.0kw _ 999.9kw	2.5kw	√
PE-43	Flow point 0 of PQ curve	0.0 _ 999.9m ³ /h	0.0 m ³ /h	√
PE-44	Flow point 1 of PQ curve	0.0 _ 999.9m ³ /h	5.0 m ³ /h	√
PE-45	Flow point 2 of PQ curve	0.0 _ 999.9m ³ /h	10.0m ³ /h	√
PE-46	Flow point 3 of PQ curve	0.0 _ 999.9m ³ /h	15.0m ³ /h	√
PE-47	Flow point 4 of PQ curve	0.0 _ 999.9m ³ /h	20.0m ³ /h	√
PE-48	Initiating frequency of	0.00 _ 320.00Hz	0.0Hr	√

SUMO SU200 High Performance Frequency Inverter

Function code	Name	Setting range	Factory setting	Modification
	dry run protection			
PE-49	Sleep power detecting selection When PE-49=0, the sleep mode activating as voltage . When PE-49 not set for 0, inveter if go to sleep mode as sleep power detecting .	0.0% - 100.0%	0.0%	√
PE-50	Detecting time of sleep power	0 ~ 30000sec	60sec	√
PE-51	Sleep frequency	0.00Hz ~ 300.00Hz	10.00Hz	√

Charter 7 Monitor parameters of Inverter

Monitor parameters	Monitoring contents	Unit	Address
U0-00	Running frequency(Hz)	0.01Hz	7000H
U0-01	Set frequency (Hz)	0.01Hz	7001H
U0-02	DC Bus voltage (V)	0.1V	7002H
U0-03	Output voltage (V)	1V	7003H
U0-04	Output current (A)	0.01A	7004H
U0-05	Output power (KW)	0.1KW	7005H
U0-06	Output torque(%)	0.1%	7006H
U0-07	DI input status	1	7007H
U0-08	DO output status	1	7008H
U0-09	A11 Voltage (V)	0.01V	7009H
U0-10	A12 Voltage (V)	0.01V	700AH
U0-11	Keyboard potentiometer voltage (V)	0.01V	700BH
U0-12	Count value	1	700CH
U0-13	Length value	1	700DH
U0-14	Load speed display	1	700EH
U0-15	PID setting	1	700FH
U0-16	PID feedback	1	7010H
U0-17	PLC stage	1	7011H
U0-18	PULSE input pulse frequency (Hz)	0.01kHz	7012H
U0-19	Feedback speed (Hz)	0.01Hz	7013H
U0-20	Remaining run time	0.1Min	7014H
U0-21	A11 before correction voltage	0.001V	7015H
U0-22	A12 before correction voltage	0.001V	7016H
U0-23	Keyboard potentiometer before calibration	0.001V	7017H
U0-24	Line speed	1m/Min	7018H
U0-25	Current power up time	1Min	7019H
U0-26	Current run time	0.1Min	701AH
U0-27	PULSE input pulse frequency	1Hz	701BH
U0-28	Communication setpoint	0.01%	701CH
U0-29	Encoder feedback speed	0.01Hz	701DH

SUMO SU200 High Performance Frequency Inverter

U0-30	The main frequency X is displayed	0.01Hz	701EH
U0-31	Secondary frequency Y display	0.01Hz	701FH
U0-32	View any memory address values	1	7020H
U0-33	Synchrotron rotor position	0.1°	7021H
U0-34	Motor temperature value	1°C	7022H
U0-35	Target Torque (%)	0.1%	7023H
U0-36	Rotary transformer position	1	7024H
U0-37	Power factor angle	0.1°	7025H
U0-38	ABZ position	1	7026H
U0-39	The target voltage in VF separates	1V	7027H
U0-40	The output voltage in VF separates	1V	7028H
U0-41	Visual display of DI input status	1	7029H
U0-42	Visual display of DO output status	1	702AH
U0-43	Visual display of DI function status (function 01 to function 40)	1	702BH
U0-44	Visual display of DI function status (function 41 to function 80)	1	702CH
U0-45	Alarm information	1	702DH
U0-58	Z signal counter	1	703AH
U0-59	Set frequency (%)	0.01%	703BH
U0-60	Running frequency (%)	0.01%	703CH
U0-61	Inverter (inverter) status	1	703DH

Note: When AC inverter configured solar pump control purpose function with MPPT.

Monitor parameters has been change, please take below for reference.

Monitor parameters	Monitoring contents	Unit	Address
U0-00	Output frequency	0.01Hz	7000H
U0-01	Preset frequency	0.01Hz	7001H
U0-02	DC voltage of PV arrays	0.1V	7002H
U0-03	Output voltage	1V	7003H
U0-04	Output current	0.01A	7004H
U0-05	Power of PV arrays	0.1KW	7005H
U0-06	Current of PV arrays	0.01A	7006H
U0-07	DI input status	1	7007H
U0-08	DO output status	1	7008H
U0-09	AI1	0.01V	7009H
U0-10	AI2	0.01V	700AH
U0-11	Motor (pump) speed	1rpm	700BH
U0-12	PV open loop circuit voltage (Voc)	0.1V	700CH
U0-13	Flow rate of pump	0.1m ³ /hr	700DH
U0-14	Day flow	0.1m ³	700EH
U0-15	Flow accumulation (low-order digit)	0.1m ³	700FH
U0-16	flow accumulation (low-order digit)	0.1Km ³	7010H
U0-17	Day generated power	0.1kwh	7011H
U0-18	Generated accumulation (low-order digit)	0.1kwh	7012H
U0-19	Generated accumulation (high-order digit)	0.1Mwh	7013H
U0-20	The rest running time	0.1Min	7014H
U0-24	Pump running speed	r/min	7018H
U0-25	Current power up time	1min	7019H
U0-26	Current running time	0.1min	701AH
U0-45	Fault information	1	702DH
U0-61	Inverter working status	1	703DH

Chapter 8 Description of Function Codes

Function Code	Parameter Name	Setting Range	Default
P0-15	Carrier frequency	0.5–16.0 kHz	Per model

It is used to adjust the carrier frequency of the Inverter, helping to reduce the motor noise, avoiding the resonance of the mechanical system, and reducing the leakage current to the earth and interference generated by the Inverter.

If the carrier frequency is low, output current has high harmonics, and the power loss and temperature rise of the motor increase.

If the carrier frequency is high, power loss and temperature rise of the motor declines. However, the Inverter has an increase in power loss, temperature rise and interference

Carrier frequency	Low	High
Motor noise	Large	Small
Output current waveform	Bad	Good
Motor temperature rise	High	Low
Inverter temperature rise	Low	High
Leakage current	Small	Large
External radiation interference	Small	Large

The factory setting of carrier frequency varies with the Inverter power. If you need to modify the carrier frequency, note that if the set carrier frequency is higher than factory setting, it will lead to an increase in temperature rise of the Inverter's heatsink. In this case, you need to de-rate the Inverter. Otherwise, the Inverter may overheat and alarm.

Function Code	Parameter Name	Setting Range	Default
P0-16	Carrier frequency adjustment with temperature	0: No 1: Yes	1

It is used to set whether the carrier frequency is adjusted based on the temperature. The Inverter automatically reduces the carrier frequency when detecting that the heatsink temperature is high. The Inverter resumes the carrier frequency to the set value when the heatsink temperature becomes normal. This function reduces the overheat alarms.

Function Code	Parameter Name	Setting Range	Default
P1-37	Auto-tuning selection	0: No auto-tuning 1: Asynchronous motor static auto-tuning 2: Asynchronous motor complete auto-tuning 11: Synchronous motor with-load auto-tuning 12: Synchronous motor no-load auto-tuning	0

- 0: No auto-tuning Auto tuning is prohibited.

- 1: Asynchronous motor static auto-tuning

It is applicable to scenarios where complete auto-tuning cannot be performed because the asynchronous motor cannot be disconnected from the load.

Before performing static auto-tuning, properly set the motor type and motor nameplate parameters of P1-00 to P1-05 first. The Inverter will obtain parameters of P1-06 to P1-08 by static auto-tuning.

Set this parameter to 1, and press . Then, the Inverter starts static auto-tuning.

- 2: Asynchronous motor complete auto-tuning

To perform this type of auto-tuning, ensure that the motor is disconnected from the load. During the process of complete auto-tuning, the Inverter performs static auto-tuning first and then accelerates to 80% of the rated motor frequency within the acceleration time set in P0-17. The Inverter keeps running for a certain period and then decelerates to stop within deceleration time set in P0-18.

Group P4: Input Terminals

The SU200 provides five DI terminals (DI5 can be used for high-speed pulse input) and two analog input (AI) terminals. The optional extension card provides another five DI terminals (DI6 to DI10) and an analog input(keypad potentiometer).

Function Code	Parameter Name	Default	Remark
P4-00	DI1 function selection	1: Forward RUN (FWD)	Standard
P4-01	DI2 function selection	4: Forward JOG (FJOG)	Standard
P4-02	DI3 function selection	9: Fault reset (RESET)	Standard
P4-03	DI4 function selection	12: Multi-reference terminal 1	Standard
P4-04	DI5 function selection	13: Multi-reference terminal 2	Standard
P4-05	DI6 function selection	0	Extended
P4-06	DI7 function selection	0	Extended
P4-07	DI8 function selection	0	Extended
P4-08	DI9 function selection	0	Extended
P4-09	DI10 function selection	0	Extended

The following table lists the functions available for the DI terminals.

Table 6-1 Functions of DI terminals

Value	Function	Description
-------	----------	-------------

0	No function	Set 0 for reserved terminals to avoid malfunction.
1	Forward RUN (FWD)	The terminal is used to control forward or reverse RUN of the Inverter.
2	Reverse RUN (REV)	
3	Three-line control	The terminal determines three-line control of the AC drive. For details, see the description of F4-11.
4	Forward JOG (FJOG)	FJOG indicates forward JOG running, while RJOG indicates reverse JOG running. The JOG frequency, acceleration time and deceleration time are described respectively in P8-00, P8-01 and P8-02.
5	Reverse JOG (RJOG)	
6	Terminal UP	If the frequency is determined by external terminals, the terminals with the two functions are used as increment and decrement commands for frequency modification. When the frequency source is digital setting, they are used to adjust the frequency.
7	Terminal DOWN	
8	Coast to stop	The Inverter blocks its output, the motor coasts to rest and is not controlled by the Inverter. It is the same as coast to stop described in P6-10.
9	Fault reset (RESET)	The terminal is used for fault reset function, the same as the function of RESET key on the operation panel. Remote fault reset is implemented by this function.

Value	Function	Description
10	RUN pause	The Inverter decelerates to stop, but the running parameters are all memorized, such as PLC, swing frequency and PID parameters. After this function is disabled, the Inverter resumes its status before stop.
11	Normally open (NO) input of external fault	If this terminal becomes ON, the Inverter reports Err15 and performs the fault protection action. For more details, see the description of P9-47.
12	Multi-reference terminal 1	The setting of 16 speeds or 16 other references can be implemented through combinations of 16 states of these four terminals.
13	Multi-reference terminal 2	
14	Multi-reference terminal 3	
15	Multi-reference terminal 4	
16	Terminal 1 for acceleration/ deceleration time selection	Totally four groups of acceleration/deceleration time can be selected through combinations of two states of these two terminals.
17	Terminal 2 for acceleration/ deceleration time selection	
18	Frequency source switchover	The terminal is used to perform switchover between two frequency sources according to the setting in P0-07.
19	UP and DOWN setting clear (terminal, operation panel)	If the frequency source is digital setting, the terminal is used to clear the modification by using the UP/ DOWN function or the increment/decrement key on the operation panel, returning the set frequency to the value of F0-08.
20	Command source switchover terminal	If the command source is set to terminal control (F0-02 = 1), this terminal is used to perform switchover between terminal control and operation panel control. If the command source is set to communication control (P0-02 = 2), this terminal is used to perform switchover between communication control and operation panel control.
21	Acceleration/Deceleration prohibited	It enables the Inverter to maintain the current frequency output without being affected by external signals (except the STOP command).
22	PID pause	PID is invalid temporarily. The Inverter maintains the current frequency output without supporting PID adjustment of frequency source.
23	PLC status reset	The terminal is used to restore the original status of PLC control for the Inverter when PLC control is started again after a pause.
24	Swing pause	The Inverter outputs the central frequency, and the swing frequency function pauses.
25	Counter input	This terminal is used to count pulses.
26	Counter reset	This terminal is used to clear the counter status.
27	Length count input	This terminal is used to count the length.
28	Length reset	This terminal is used to clear the length.

Value	Function	Description
29	Torque control prohibited	The Inverter is prohibited from torque control and enters the speed control mode.
30	Pulse input (enabled only for DI5)	DI5 is used for pulse input.
31	Reserved	Reserved.
32	Immediate DC braking	After this terminal becomes ON, the Inverter directly switches over to the DC braking state.
33	Normally closed (NC) input of external fault	After this terminal becomes ON, the Inverter reports Err15 and stops.
34	Frequency modification forbidden	After this terminal becomes ON, the Inverter does not respond to any frequency modification.
35	Reverse PID action direction	After this terminal becomes ON, the PID action direction is reversed to the direction set in PA-03.
36	External STOP terminal 1	In operation panel mode, this terminal can be used to stop the Inverter, equivalent to the function of the STOP key on the operation panel.
37	Command source switchover terminal 2	It is used to perform switchover between terminal control and communication control. If the command source is terminal control, the system will switch over to communication control after this terminal becomes ON.
38	PID integral pause	After this terminal becomes ON, the integral adjustment function pauses. However, the proportional and differentiation adjustment functions are still valid.
39	Switchover between main frequency source X and preset frequency	After this terminal becomes ON, the frequency source X is replaced by the preset frequency set in F0-08.
40	Switchover between auxiliary frequency source Y and preset frequency	After this terminal is enabled, the frequency source Y is replaced by the preset frequency set in F0-08.
41	Motor selection terminal 1	Switchover among the four groups of motor parameters can be implemented through the four state combinations of these two terminals.
42	Motor selection terminal 2	
43	PID parameter switchover	If the PID parameters switchover performed by means of DI terminal (PA-18 = 1), the PID parameters are PA-05 to PA-07 when the terminal becomes OFF; the PID parameters are PA-15 to PA-17 when this terminal becomes ON.
44	User-defined fault 1	If these two terminals become ON, the Inverter reports Err27 and Err28 respectively, and performs fault protection actions based on the setting in P9-49.
45	User-defined fault 2	
46	Speed control/Torque control switchover	This terminal enables the Inverter to switch over between speed control and torque control. When this terminal becomes OFF, the Inverter runs in the mode set in A0-00. When this terminal becomes ON, the AC drive switches over to the other control mode.

Value	Function	Description
47	Emergency stop	When this terminal becomes ON, the Inverter stops within the shortest time. During the stop process, the current remains at the set current upper limit. This function is used to satisfy the requirement of stopping the Inverter in emergency state.
48	External STOP terminal 2	In any control mode (operation panel, terminal or communication), it can be used to make the Inverter decelerate to stop. In this case, the deceleration time is deceleration time 4.
49	Deceleration DC braking	When this terminal becomes ON, the Inverter decelerates to the initial frequency of stop DC braking and then switches over to DC braking state.
50	Clear the current running time	When this terminal becomes ON, the Inverter's current running time is cleared. This function must be supported by P8-42 and P8-53.
51	Switchover between two-line mode and three-line mode	It is used to perform switchover between two-line control and three-line control. If P4 -11 is set to Two-line mode 1, the system switches over to three-line mode 1 when the DI allocated with this function becomes ON

The four multi-reference terminals have 16 state combinations, corresponding to 16 reference values, as listed in the following table.

Below table State combinations of the four multi-reference terminals

K4	K3	K2	K1	Reference Setting	Corresponding Parameter
OFF	OFF	OFF	OFF	Reference 0	FC-00
OFF	OFF	OFF	ON	Reference 1	FC-01
OFF	OFF	ON	OFF	Reference 2	FC-02
OFF	OFF	ON	ON	Reference 3	FC-03
OFF	ON	OFF	OFF	Reference 4	FC-04
OFF	ON	OFF	ON	Reference 5	FC-05
OFF	ON	ON	OFF	Reference 6	FC-06
OFF	ON	ON	ON	Reference 7	FC-07
ON	OFF	OFF	OFF	Reference 8	FC-08
ON	OFF	OFF	ON	Reference 9	FC-09
ON	OFF	ON	OFF	Reference 10	FC-10
ON	OFF	ON	ON	Reference 11	FC-11
ON	ON	OFF	OFF	Reference 12	FC-12
ON	ON	OFF	ON	Reference 13	FC-13
ON	ON	ON	OFF	Reference 14	FC-14
ON	ON	ON	ON	Reference 15	FC-15

If the frequency source is multi-reference, the value 100% of PC-00 to PC-15 corresponds to the value of P0-10 (Maximum frequency).

Besides the multi-speed function, the multi-reference can be also used as the PID setting source or the voltage source for V/F separation, satisfying the requirement on switchover of different setting values.

Two terminals for acceleration/deceleration time selection have four state combinations, as listed in the following table.

Below table state combinations of two terminals for acceleration/deceleration time selection

Terminal 2	Terminal 1	Acceleration/Deceleration Time Selection	Corresponding Parameters
OFF	OFF	Acceleration/Deceleration time 1	P0-17, P0-18
OFF	ON	Acceleration/Deceleration time 2	P8-03, P8-04
ON	OFF	Acceleration/Deceleration time 3	P8-05, P8-06
ON	ON	Acceleration/Deceleration time 4	P8-07, P8-08

Two motor selection terminals have four state combinations, corresponding to four motors, as listed in the following table.

Below table state combinations of two motor selection terminals

Terminal 2	Terminal 1	Selected Motor	Corresponding Parameters
OFF	OFF	Motor 1	Group P1, Group P2
OFF	ON	Motor 2	Group A2
ON	OFF	Motor 3	Group A3
ON	ON	Motor 4	Group A4

Function Code	Parameter Name	Setting Range	Default
P4-10	DI filter time	0.000–1.000s	0.010s

It is used to set the software filter time of DI terminal status. If DI terminals are liable to interference and may cause malfunction, increase the value of this parameter to enhance the anti-interference capability. However, increase of DI filter time will reduce the response of DI terminals.

Function Code	Parameter Name	Setting Range	Default
P4-11	Terminal command mode	0: Two-line mode 1 1: Two-line mode 2 2: Three-line mode 1 3: Three-line mode 2	0

This parameter is used to set the mode in which the Inverter is controlled by external terminals. The following uses DI1, DI2 and DI3 among DI1 to DI10 as an example, with allocating functions of DI1, DI2 and DI3 by setting P4-00 to P4-02.

- 0: Two-line mode 1

It is the most commonly used two-line mode, in which the forward/reverse rotation of the motor is decided by DI1 and DI2. The parameters are set as below:

Function Code	Parameter Name	Value	Function Description
P4-11	Terminal command mode	0	Two-line 1
P4-00	DI1 function selection	1	Forward RUN (FWD)
P4-01	DI2 function selection	2	Reverse RUN (REV)

Setting of two-line mode 1

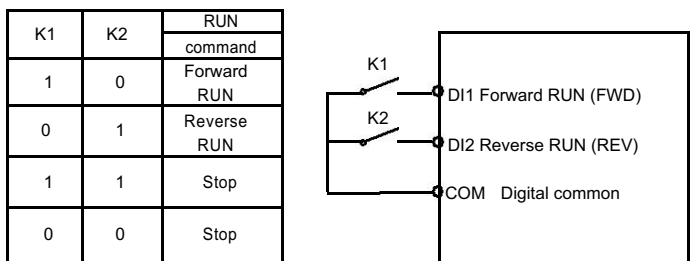

As shown in the preceding figure, when only K1 is ON, the Inverter instructs forward rotation. When only K2 is ON, the Inverter instructs reverse rotation. When K1 and K2 are ON or OFF simultaneously, the Inverter stops

- 1: Two-line mode 2

In this mode, DI1 is RUN enabled terminal, and DI2 determines the running direction. The parameters are set as below:

Function Code	Parameter Name	Value	Function Description
P4-11	Terminal command mode	1	Two-line 2
P4-00	DI1 function selection	1	RUN enabled
P4-01	DI2 function selection	2	Forward or reverse direction

Setting of two-line mode 2

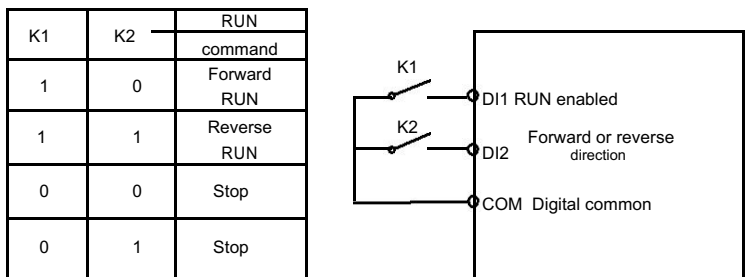

As shown in the preceding figure, if K1 is ON, the Inverter instructs forward rotation when K2 is OFF, and instructs reverse rotation when K2 is ON. If K1 is OFF, the Inverter stops.

- 2: Three-line mode 1

In this mode, DI3 is RUN enabled terminal, and the direction is decided by DI1 and DI2. The parameters are set as below:

Function Code	Parameter Name	Value	Function Description
P4-11	Terminal command mode	2	Three-line 1
P4-00	DI1 function selection	1	Forward RUN (FWD)
P4-01	DI2 function selection	2	Reverse RUN (REV)
P4-02	DI3 function selection	3	Three-line control

Setting of three-line mode 1

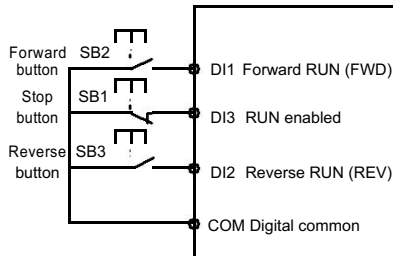

As shown in the preceding figure, if SB1 is ON, the Inverter instructs forward rotation when SB2 is pressed to be ON and instructs reverse rotation when SB3 is pressed to be ON. The Inverter stops immediately after SB1 becomes OFF. During normal startup and running, SB1 must remain ON. The Inverter's running state is determined by the final actions on SB1, SB2 and SB3.

- 3: Three-line mode 2

In this mode, DI3 is RUN enabled terminal. The RUN command is given by DI1 and the direction is decided by DI2. The parameters are set as below:

Function Code	Parameter Name	Value	Function Description
P4-11	Terminal command mode	3	Three-line 2
P4-00	DI1 function selection	1	RUN enabled
P4-01	DI2 function selection	2	Forward or reverse direction
P4-02	DI3 function selection	3	Three-line control

Setting of three-line mode 2

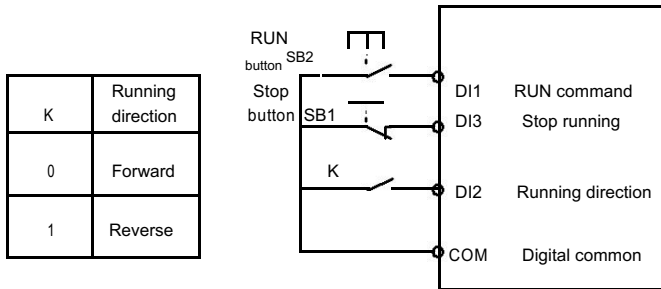

As shown in the preceding figure, if SB1 is ON, the Inverter starts running when SB2 is pressed to be ON; the Inverter instructs forward rotation when K is OFF and instructs reverse rotation when K is ON. The Inverter stops immediately after SB1 becomes OFF. During normal startup and running, SB1 must remain ON. The Inverter's running state is determined by the final actions of SB1, SB2 and K.

Group P5: Output Terminals

The SU200 provides an analog output (AO) terminal, a digital output (DO) terminal, a relay terminal and a FM terminal (used for high-speed pulse output or open-collector switch signal output) as standard. If these output terminals cannot satisfy requirements, use an optional I/O extension card that provides an AO terminal (AO2), a relay terminal (relay 2) and a DO terminal (DO2).

Function Code	Parameter Name	Setting Range	Default
P5-00	FM terminal output mode	0: Pulse output (FMP) 1: Switch signal output (FMR)	0

The FM terminal is programmable multiplexing terminal. It can be used for high-speed pulse output (FMP), with maximum frequency of 50 kHz. Refer to P5-06 for relevant functions of FMP. It can also be used as open collector switch signal output (FMR).

Function Code	Parameter Name	Default
P5-01	FMR function (open-collector output terminal)	0
P5-02	Relay function (T/A-T/B-T/C)	2
P5-03	Extension card relay function (P/A-P/B-P/C)	0
P5-04	DO1 function selection (open-collector output terminal)	1
P5-05	Extension card DO2 function	4

These five parameters are used to select the functions of the five digital output terminals. T/A-T/B-T/C and P/A-P/B-P/C are respectively the relays on the control board and the extension card.

The functions of the output terminals are described in the following table.

Value	Function	Description
0	No output	The terminal has no function.
1	Inverter running	When the Inverter is running and has output frequency (can be zero), the terminal becomes ON.
2	Fault output (stop)	When the Inverter stops due to a fault, the terminal becomes ON.
3	Frequency-level detection FDT1 output	Refer to the descriptions of P8-19 and P8-20.
4	Frequency reached	Refer to the descriptions of P8-21.
5	Zero-speed running (no output at stop)	If the Inverter runs with the output frequency of 0, the terminal becomes ON. If the Inverter is in the stop state, the terminal becomes OFF.
6	Motor overload pre-warning	The Inverter judges whether the motor load exceeds the overload pre-warning threshold before performing the protection action. If the pre-warning threshold is exceeded, the terminal becomes ON. For motor overload parameters, see the descriptions of P9-00 to P9-02.
7	Inverter overload pre-warning	The terminal becomes ON 10s before the Inverter overload protection action is performed.
8	Set count value reached	The terminal becomes ON when the count value reaches the value set in PB-08.
9	Designated count value reached	The terminal becomes ON when the count value reaches the value set in PB-09.
10	Length reached	The terminal becomes ON when the detected actual length exceeds the value set in PB-05.
11	PLC cycle complete	When simple PLC completes one cycle, the terminal outputs a pulse signal with width of 250 ms.
12	Accumulative running time reached	If the accumulative running time of the Inverter exceeds the time set in P8-17, the terminal becomes ON.
13	Frequency limited	If the set frequency exceeds the frequency upper limit or lower limit and the output frequency of the Inverter reaches the upper limit or lower limit, the terminal becomes ON.
14	Torque limited	In speed control mode, if the output torque reaches the torque limit, the Inverter enters the stall protection state and meanwhile the terminal becomes ON.
15	Ready for RUN	If the Inverter main circuit and control circuit become stable, and the Inverter detects no fault and is ready for RUN, the terminal becomes ON.
16	AI1 larger than AI2	When the input of AI1 is larger than the input of AI2, the terminal becomes ON.
17	Frequency upper limit reached	If the running frequency reaches the upper limit, the terminal becomes ON.
18	Frequency lower limit reached (no output at stop)	If the running frequency reaches the lower limit, the terminal becomes ON. In the stop state, the terminal becomes OFF.

Value	Function	Description
19	Under voltage state output	If the Inverter is in under voltage state, the terminal becomes ON.
20	Communication setting	Refer to the communication protocol.
21	Reserved	Reserved.
22	Reserved	Reserved.
23	Zero-speed running 2 (having output at stop)	If the output frequency of the Inverter is 0, the terminal becomes ON. In the state of stop, the signal is still ON.
24	Accumulative power-on time reached	If the Inverter accumulative power-on time (P7-13) exceeds the value set in P8-16, the terminal becomes ON.
25	Frequency level detection FDT2 output	Refer to the descriptions of P8-28 and P8-29.
26	Frequency 1 reached	Refer to the descriptions of P8-30 and P8-31.
27	Frequency 2 reached	Refer to the descriptions of P8-32 and P8-33.
28	Current 1 reached	Refer to the descriptions of P8-38 and P8-39.
29	Current 2 reached	Refer to the descriptions of P8-40 and P8-41.
30	Timing reached	If the timing function (P8-42) is valid, the terminal becomes ON after the current running time of the Inverter reaches the set time.
31	AI1 input limit exceeded	If AI1 input is larger than the value of P8-46 (AI1 input voltage upper limit) or lower than the value of P8-45 (AI1 input voltage lower limit), the terminal becomes ON.
32	Load becoming 0	If the load becomes 0, the terminal becomes ON.
33	Reverse running	If the Inverter is in the reverse running state, the terminal becomes ON.
34	Zero current state	Refer to the descriptions of P8-28 and P8-29.
35	IGBT temperature reached	If the heatsink temperature of the Inverter IGBT (P7-07) reaches the set IGBT temperature threshold (P8-47), the terminal becomes ON.
36	Software current limit exceeded	Refer to the descriptions of P8-36 and P8-37.
37	Frequency lower limit reached (having output at stop)	If the running frequency reaches the lower limit, the terminal becomes ON. In the stop state, the signal is still ON.
38	Alarm output	If a fault occurs on the Inverter and the Inverter continues to run, the terminal outputs the alarm signal.
39	Motor overheat warning	If the motor temperature reaches the temperature set in P9-58 (Motor overheat warning threshold), the terminal becomes ON. You can view the motor temperature by using U0-34.
40	Current running time reached	If the current running time of Inverter exceeds the value of P8-53, the terminal becomes ON.

Function Code	Parameter Name	Default
P5-06	FMP function selection	0
P5-07	AO1 function selection	0
P5-08	AO2 function selection	1

The output pulse frequency of the FMP terminal ranges from 0.01 kHz to "Maximum FMP output frequency" (P5-09). The value of P5-09 is between 0.01 kHz and 100.00 kHz.

The output range of AO1 and AO2 is 0–10 V or 0–20 mA. The relationship between pulse and analog output ranges and corresponding functions is listed in the following table.

Relationship between pulse and analog output ranges and corresponding functions

Value	Function	Range (Corresponding to Pulse or Analog Output Range 0.0%–100.0%)
0	Running frequency	0 to maximum output frequency
1	Set frequency	0 to maximum output frequency
2	Output current	0 to 2 times of rated motor current
3	Output torque (absolute value)	0 to 2 times of rated motor torque
4	Output power	0 to 2 times of rated power
5	Output voltage	0 to 1.2 times of rated Inverter voltage
6	Pulse input	0.01–100.00 kHz
7	AI1	0–10 V
8	AI2	0–10 V (or 0–20 mA)
9	AI3	0–0 V
10	Length	0 to maximum set length
11	Count value	0 to maximum count value
12	Communication setting	0.0%–100.0%
13	Motor rotational speed	0 to rotational speed corresponding to maximum output frequency
14	Output current	0.0–1000.0 A
15	Output voltage	0.0–000.0 V
16	Output torque (actual value)	-2 times of rated motor torque to 2 times of rated motor torque

Function Code	Parameter Name	Setting Range	Default
P5-09	Maximum FMP output frequency	0.01–100.00 kHz	50.00 kHz

If the FM terminal is used for pulse output, this parameter is used to set the maximum frequency of pulse output

Function Code	Parameter Name	Setting Range	Default
P7-01	MF.K Key function selection	0: MF.K key disabled 1: Switchover between operation panel control and remote command control (terminal or communication) 2: Switchover between forward rotation and reverse rotation 3: Forward JOG 4: Reverse JOG	0

MF.K key refers to multifunctional key. You can set the function of the MF.K key by using this parameter. You can perform switchover by using this key both in stop or running state.

- 0: MF.K key disabled
This key is disabled.
- 1: Switchover between operation panel control and remote command control (terminal or communication)
You can perform switchover from the current command source to the operation panel control (local operation). If the current command source is operation panel control, this key is invalid.
- 2: Switchover between forward rotation and reverse rotation
You can change the direction of the frequency reference by using the MF.K key. It is valid only when the current command source is operation panel control.
- 3: Forward JOG
You can perform forward JOG (FJOG) by using the MF.K key.
- 4: Reverse JOG
You can perform reverse JOG (FJOG) by using the MF.K key.

Function Code	Parameter Name	Setting Range	Default
P7-02	STOP/RESET key function	0: STOP/RESET key enabled only in operation panel control 1: STOP/RESET key enabled in any operation mode	1

Function Code	Parameter Name	Setting Range	Default
P7-03	LED display running parameters 1	<p>0000–FFFF</p> <p>7 6 5 4 3 2 1 0</p> <ul style="list-style-type: none"> Running frequency 1 (Hz) Set frequency (Hz) Bus voltage (V) Output voltage (V) Output current (A) Output power (kW) Output torque (%) DI input status (V) <p>15 14 13 12 11 10 9 8</p> <ul style="list-style-type: none"> DO output status AI1 voltage (V) AI2 voltage (V) AI3 voltage (V) Count value Length value Load speed display PID setting <p>If a parameter needs to be displayed during the running, set the corresponding bit to 1, and set P7-03 to the hexadecimal equivalent of this binary number.</p>	1F

Function Code	Parameter Name	Setting Range	Default
P7-04	LED display running parameters 2	0000-FFFF 	0
		If a parameter needs to be displayed during the running, set the corresponding bit to 1, and set P7-03 to the hexadecimal equivalent of this binary number.	

These two parameters are used to set the parameters that can be viewed when the Inverter is in the running state. You can view a maximum of 32 running state parameters that are displayed from the lowest bit of P7-03.

Function Code	Parameter Name	Setting Range	Default
P7-05	LED display stop parameters	0000–FFFF 	0
If a parameter needs to be displayed during the running, set the corresponding bit to 1, and set P7-05 to the hexadecimal equivalent of this binary number.			

Function Code	Parameter Name	Setting Range	Default
P7-06	Load speed display coefficient	0.0001–6.5000	1.0000

This parameter is used to adjust the relationship between the output frequency of the inverter and the load speed. For details, see the description of P7-12.

Function Code	Parameter Name	Setting Range	Default
P7-07	Heatsink temperature of Inverter IGBT	0.0–100.0°C	-

It is used to display the insulated gate bipolar transistor (IGBT) temperature of the Inverter IGBT, and the IGBT overheat protection value of the Inverter IGBT depends on the model.

Function Code	Parameter Name	Setting Range	Default
P7-08	Temporary software version	0.0–100.0°C	-

It is used to display the temporary software version of the control board.

Function Code	Parameter Name	Setting Range	Default
P7-09	Accumulative running time	0–65535 h	-

It is used to display the accumulative running time of the Inverter. After the accumulative running time reaches the value set in P8-17, the terminal with the digital output function 12 becomes ON.

Function Code	Parameter Name	Setting Range	Default
P7-10	Product number	Inverter product number	-
P7-11	Software version	Software version of control board	-
P7-12	Number of decimal places for load speed display	0: 0 decimal place 1: 1 decimal place 2: 2 decimal places 3: 3 decimal places	1

P7-12 is used to set the number of decimal places for load speed display. The following gives an example to explain how to calculate the load speed:

Assume that P7-06 (Load speed display coefficient) is 2.000 and P7-12 is 2 (2 decimal places). When the running frequency of the Inverter is 40.00 Hz, the load speed is $40.00 \times 2.000 = 80.00$ (display of 2 decimal places).

If the Inverter is in the stop state, the load speed is the speed corresponding to the set frequency, namely, "set load speed". If the set frequency is 50.00 Hz, the load speed in the stop state is $50.00 \times 2.000 = 100.00$ (display of 2 decimal places).

Function Code	Parameter Name	Setting Range	Default
P7-13	Accumulative power-on time	0–65535 h	0 h

It is used to display the accumulative power-on time of the Inverter since the delivery. If the time reaches the set power-on time (P8-17), the terminal with the digital output function 24 becomes ON.

Function Code	Parameter Name	Setting Range	Default
P7-14	Accumulative power consumption	0–65535 kWh	/

It is used to display the accumulative power consumption of the Inverter until now.

Group P8: Auxiliary Functions

Function Code	Parameter Name	Setting Range	Default
P8-00	JOG running frequency	0.00 Hz to maximum frequency	2.00 Hz
P8-01	JOG acceleration time	0.0–6500.0s	20.0s
P8-02	JOG deceleration time	0.0–6500.0s	20.0s

These parameters are used to define the set frequency and acceleration/deceleration time of the Inverter when jogging. The startup mode is "Direct start" (P6-00 = 0) and the stop mode is "Decelerate to stop" (P6-10 = 0) during jogging.

Function Code	Parameter Name	Setting Range	Default
P8-03	Acceleration time 2	0.0–6500.0s	Model dependent

Function Code	Parameter Name	Setting Range	Default
P8-04	Deceleration time 2	0.0–6500.0s	Model dependent
P8-05	Acceleration time 3	0.0–6500.0s	Model dependent
P8-06	Deceleration time 3	0.0–6500.0s	Model dependent
P8-07	Acceleration time 4	0.0–500.0s	Model dependent
P8-08	Deceleration time 4	0.0–6500.0s	Model dependent

The SU200 inverter provides a total of four groups of acceleration/deceleration time, that is, the preceding three groups and the group defined by P0-17 and P0-18. Definitions of four groups are completely the same. You can switch over between the four groups of acceleration/deceleration time through different state combinations of DI terminals. For more details, see the descriptions of P4-01 to P4-05.

Function Code	Parameter Name	Setting Range	Default
P8-09	Jump frequency 1	0.00 Hz to maximum frequency	0.00 Hz
P8-10	Jump frequency 2	0.00 Hz to maximum frequency	0.00 Hz
P8-11	Frequency jump amplitude	0.00 Hz to maximum frequency	0.00 Hz

If the set frequency is within the frequency jump range, the actual running frequency is the jump frequency close to the set frequency. Setting the jump frequency helps to avoid the mechanical resonance point of the load.

The SU200 supports two jump frequencies. If both are set to 0, the frequency jump function is disabled. The principle of the jump frequencies and jump amplitude is shown in the following figure.

Figure 6-15 Principle of the jump frequencies and jump amplitude

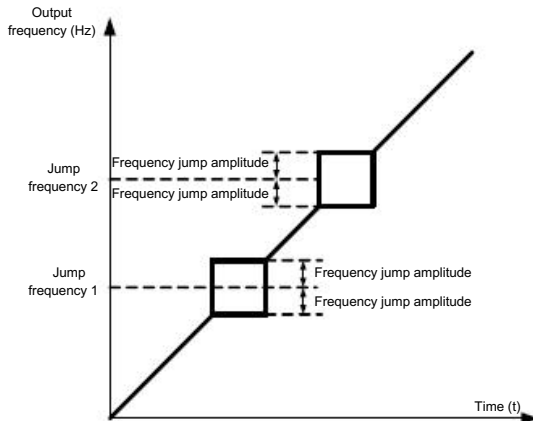

Function Code	Parameter Name	Setting Range	Default
P8-13	Reverse control	0: Enabled 1: Disabled	0

It is used to set whether the Inverter allows reverse rotation. In the applications where reverse rotation is prohibited, set this parameter to 1.

Function Code	Parameter Name	Setting Range	Default
P8-14	Running mode when set frequency lower than frequency lower limit	0: Run at frequency lower limit 1: Stop 2: Run at zero speed	0

It is used to set the Inverter running mode when the set frequency is lower than the frequency lower limit. The SU200 provides three running modes to satisfy requirements of various applications.

Function Code	Parameter Name	Setting Range	Default
P8-15	Droop control	0.00–10.00 Hz	0.00 Hz

This function is used for balancing the workload allocation when multiple motors are used to drive the same load. The output frequency of the Inverters decreases as the load increases. You can reduce the workload of the motor under load by decreasing the output frequency for this motor, implementing workload balancing between multiple motors.

Function Code	Parameter Name	Setting Range	Default
P8-16	Accumulative power-on time threshold	0–65000 h	0 h

If the accumulative power -on time (P7-13) reaches the value set in this parameter, the corresponding DO terminal becomes ON.

For example, combining virtual DI/DO functions, to implement the function that the Inverter

Function Code	Parameter Name	Setting Range	Default
P8-27	Terminal JOG preferred	0: Disabled 1: Enabled	0

It is used to set whether terminal JOG is preferred.

If terminal JOG is preferred, the Inverter switches to terminal JOG running state when there is a terminal JOG command during the running process of the Inverter.

Function Code	Parameter Name	Setting Range	Default
P8-28	Frequency detection value (FDT2)	0.00 to maximum frequency	50.00 Hz
P8-29	Frequency detection hysteresis (FDT hysteresis 2)	0.0%–100.0% (FDT2 level)	5.0%

The frequency detection function is the same as FDT1 function. For details, refer to the descriptions of P8-19 and P8-20.

Function Code	Parameter Name	Setting Range	Default
P8-30	Any frequency reaching detection value 1	0.00 Hz to maximum frequency	50.00 Hz
P8-31	Any frequency reaching detection amplitude 1	0.0%–100.0% (maximum frequency)	0.0%
P8-32	Any frequency reaching detection value 2	0.00 Hz to maximum frequency	50.00 Hz

Function Code	Parameter Name	Setting Range	Default
P8-36	Output overcurrent threshold	0.0% (no detection) 0.1%–300.0% (rated motor current)	200.0%
P8-37	Output overcurrent detection delay time	0.00–600.00s	0.00s

If the output current of the Inverter is equal to or higher than the overcurrent threshold and the duration exceeds the detection delay time, the corresponding DO becomes ON. The output overcurrent detection function is shown in the following figure.

Figure 6-23 Output overcurrent detection

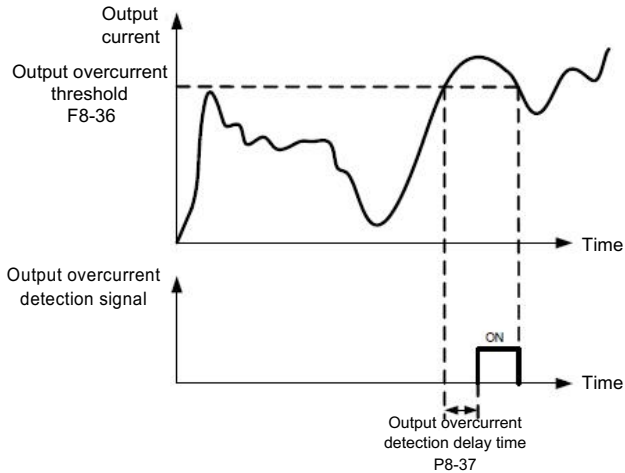

Function Code	Parameter Name	Setting Range	Default
P8-38	Any current reaching 1	0.0%–300.0% (rated motor current)	100.0%
P8-39	Any current reaching 1 amplitude	0.0%–300.0% (rated motor current)	0.0%
P8-40	Any current reaching 2	0.0%–300.0% (rated motor current)	100.0%
P8-41	Any current reaching 2 amplitude	0.0%–300.0% (rated motor current)	0.0%

If the output current of the Inverter is within the positive and negative amplitudes of any current reaching detection value, the corresponding DO becomes ON.

The SU200 provides two groups of any current reaching detection parameters, including current detection value and detection amplitudes, as shown in the following figure.

Figure 6-24 Any current reaching detection

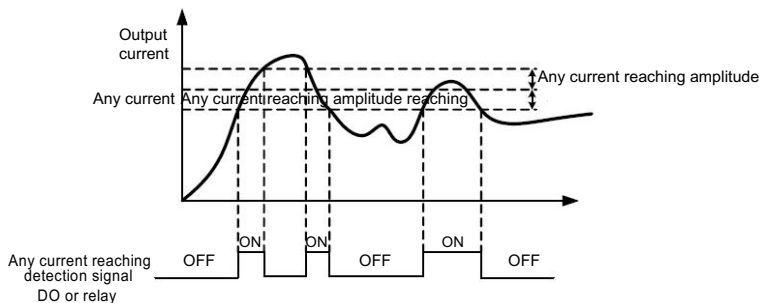

Function Code	Parameter Name	Setting Range	Default
P8-42	Timing function	0: Disabled 1: Enabled	0
P8-43	Timing duration source	0: P8-44 1: AI1 2: AI2 3: AI3 (100% of analog input corresponds to the value of P8-44)	0
P8-44	Timing duration	0.0–6500.0 min	0.0 min

These parameters are used to implement the Inverter timing function.

If P8-42 is set to 1, the Inverter starts to time at startup. When the set timing duration is reached, the Inverter stops automatically and meanwhile the corresponding DO becomes ON.

The Inverter starts timing from 0 each time it starts up and the remaining timing duration can be queried by U0-20.

The timing duration is set in P8-43 and P8-44, in unit of minute.

Function Code	Parameter Name	Setting Range	Default
P8-45	AI1 input voltage lower limit	0.00 V to F8-46	3.10 V
P8-46	AI1 input voltage upper limit	F8-45 to 10.00 V	6.80 V

These two parameters are used to set the limits of the input voltage to provide protection on the Inverter. When the AI1 input is larger than the value of P8-46 or smaller than the value of P8-45, the corresponding DO becomes ON, indicating that AI1 input exceeds the limit.

Function Code	Parameter Name	Setting Range	Default
P8-47	IGBT temperature threshold	0–75 °C	75 °C

When the heatsink temperature of the Inverter reaches the value of this parameter, the corresponding DO becomes ON, indicating that the IGBT temperature reaches the threshold.

Function Code	Parameter Name	Setting Range	Default
P8-48	Cooling fan control	0: Fan working during running 1: Fan working continuously	0

It is used to set the working mode of the cooling fan. If this parameter is set to 0, the fan works when the Inverter is in running state. When the Inverter stops, the cooling fan works if the heatsink temperature is higher than 40°C, and stops working if the heatsink temperature is lower than 40°C.

If this parameter is set to 1, the cooling fan keeps working after power-on.

Function Code	Parameter Name	Setting Range	Default
P8-49	Wakeup frequency	Dormant frequency (P8-51) to maximum frequency (P0-10)	0.00 Hz
P8-50	Wakeup delay time	0.0–6500.0s	0.0s
P8-51	Dormant frequency	0.00 Hz to wakeup frequency (P8-49)	0.00 Hz
P8-52	Dormant delay time	0.0–6500.0s	0.0s

These parameters are used to implement the dormant and wakeup functions in the water supply application.

When the Inverter is in running state, the Inverter enters the dormant state and stops automatically after the dormant delay time (P8-52) if the set frequency is lower than or equal to the dormant frequency (P8-51).

When the Inverter is in dormant state and the current running command is effective, the Inverters starts up after the wakeup delay time (P8-50) if the set frequency is higher than or equal to the wakeup frequency (P8-49).

Generally, set the wakeup frequency equal to or higher than the dormant frequency. If the wakeup frequency and dormant frequency are set to 0, the dormant and wakeup functions are disabled.

When the dormant function is enabled, if the frequency source is PID, whether PID operation is performed in the dormant state is determined by PA-28. In this case, select PID operation enabled in the stop state (PA-28 = 1).

Function Code	Parameter Name	Setting Range	Default
P8-53	Current running time reached	0.0–6500.0 min	0.0 min

If the current running time reaches the value set in this parameter, the corresponding DO becomes ON, indicating that the current running time is reached.

Function Code	Parameter Name	Setting Range	Default
P8-54	Output power correction coefficient	0.00%–200.0%	100.0%

When the output power (U0-05) is not equal to the required value, you can perform linear correction on output power by using this parameter.

Group P9: Fault and Protection

Function Code	Parameter Name	Setting Range	Default
P9-00	Motor overload protection selection	0: Disabled 1: Enabled	1
P9-01	Motor overload protection gain	0.20–10.00	1.00

- P9-00 = 0

The motor overload protective function is disabled. The motor is exposed to potential damage due to overheating. A thermal relay is suggested to be installed between the Inverter and the motor.

- P9-00 = 1

The Inverter judges whether the motor is overloaded according to the inverse time-lag curve of the motor overload protection.

The inverse time-lag curve of the motor overload protection is:

220% x P9-01 x rated motor current (if the load remains at this value for one minute, the Inverter reports motor overload fault), or

150% x P9-01 x rated motor current (if the load remains at this value for 60 minutes, the Inverter reports motor overload fault)

Set P9-01 properly based on the actual overload capacity. If the value of P9-01 is set too large, damage to the motor may result because the motor overheats but the Inverter does not report the alarm.

Function Code	Parameter Name	Setting Range	Default
P9-02	Motor overload warning coefficient	50%–100%	80%

This function is used to give a warning signal to the control system via DO before motor overload protection. This parameter is used to determine the percentage, at which pre-warning is performed before motor overload. The larger the value is, the less advanced the pre-warning will be.

When the accumulative output current of the Inverter is greater than the value of the overload inverse time-lag curve multiplied by P9-02, the DO terminal on the Inverter allocated with function 6 (Motor overload pre-warning) becomes ON.

Function Code	Parameter Name	Setting Range	Default
F9-03	Overvoltage stall gain	0 (no stall overvoltage)–100	0
F9-04	Overvoltage stall protective voltage	120%–150%	130%

When the DC bus voltage exceeds the value of P9-04 (Overvoltage stall protective voltage) during deceleration of the Inverter, the Inverter stops deceleration and keeps the present running frequency. After the bus voltage declines, the Inverter continues to decelerate.

P9-03 (Overvoltage stall gain) is used to adjust the overvoltage suppression capacity of the Inverter. The larger the value is, the greater the overvoltage suppression capacity will be.

In the prerequisite of no overvoltage occurrence, set P9-03 to a small value.

For small-inertia load, the value should be small. Otherwise, the system dynamic response will be slow. For large-inertia load, the value should be large. Otherwise, the suppression result will be poor and an overvoltage fault may occur.

If the overvoltage stall gain is set to 0, the overvoltage stall function is disabled. The overvoltage stall protective voltage setting 100% corresponds to the base values in the following table:

Overvoltage stall protective voltage setting 100% corresponds to base values

Voltage Class	Corresponding Base Value
Single-phase 220 V	290 V
Three-phase 220 V	290 V
Three-phase 380 V	530 V
Three-phase 480 V	620 V
Three-phase 690 V	880 V

Function Code	Parameter Name	Setting Range	Default
P9-05	Overcurrent stall gain	0–100	20
P9-06	Overcurrent stall protective current	100%–200%	150%

When the output current exceeds the overcurrent stall protective current during acceleration/ deceleration of the Inverter, the Inverter stops acceleration/deceleration and keeps the present running frequency. After the output current declines, the Inverter continues to accelerate/decelerate.

P9-05 (Overcurrent stall gain) is used to adjust the overcurrent suppression capacity of the Inverter. The larger the value is, the greater the overcurrent suppression capacity will be. In the prerequisite of no overcurrent occurrence, set P9-05 to a small value.

For small-inertia load, the value should be small. Otherwise, the system dynamic response will be slow. For large-inertia load, the value should be large. Otherwise, the suppression result will be poor and overcurrent fault may occur.

If the overcurrent stall gain is set to 0, the overcurrent stall function is disabled.

Figure 6-25 Diagram of the overcurrent stall protection function

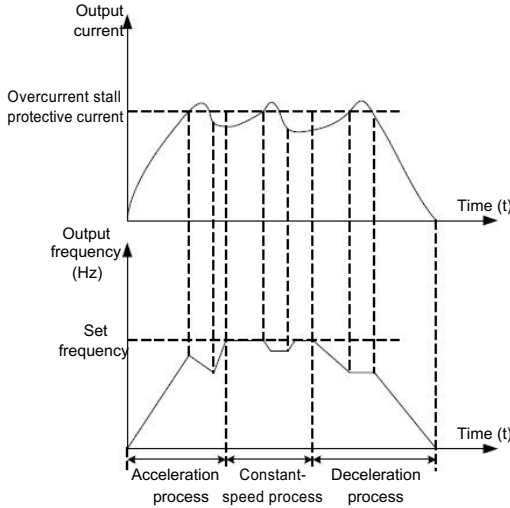

Function Code	Parameter Name	Setting Range	Default
P9-07	Short-circuit to ground upon power-on	0: Disabled 1: Enabled	1

It is used to determine whether to check the motor is short-circuited to ground at power-on of the Inverter. If this function is enabled, the Inverter's UVW will have voltage output a while after power-on.

Function Code	Parameter Name	Setting Range	Default
P9-09	Fault auto reset times	0-20	0

It is used to set the times of fault auto resets if this function is used. After the value is exceeded, the Inverter will remain in the fault state.

Function Code	Parameter Name	Setting Range	Default
P9-10	DO action during fault auto reset	0: Not act 1: Act	0

It is used to decide whether the DO acts during the fault auto reset if the fault auto reset function is selected.

Function Code	Parameter Name	Setting Range	Default
P9-11	Time interval of fault auto reset	0.1s-100.0s	1.0s

It is used to set the waiting time from the alarm of the Inverter to fault auto reset.

Function Code	Parameter Name	Setting Range	Default
P9-12	Input phase loss protection/contactor energizing protection selection	Unit's digit: Input phase loss protection Ten's digit: Contactor energizing protection 0: Disabled 1: Enabled	11

It is used to determine whether to perform input phase loss or contactor energizing protection.

The SU200 models that provide this function are listed in the following table.

SU200 models providing the input phase loss or contactor energizing protection function

Voltage Class	Models
Single-phase 220 V	None
Three-phase 220 V	11 kW G model
Three-phase 380 V	18.5 kW G model
Three-phase 690 V	18.5 kW G model

For every voltage class, the SU200 Inverters of powers equal to or greater than those listed in the preceding table provide the function of input phase loss or contactor energizing protection. The SU200 Inverters below the power listed in the table do not have the function no matter whether P9-12 is set to 0 or 1.

Function Code	Parameter Name	Setting Range	Default
P9-13	Output phase loss protection selection	0: Disabled 1: Enabled	1

It is used to determine whether to perform output phase loss protection.

Function Code	Name	Setting Range
P9-14	1st fault type	0–99
P9-15	2nd fault type	
P9-16	3rd (latest) fault type	

It is used to record the types of the most recent three faults of the Inverter. 0 indicates no fault. For possible causes and solution of each fault, refer to Chapter 7.

Function Code	Parameter Name	Description
P9-17	Frequency upon 3rd fault	It displays the frequency when the latest fault occurs.
P9-18	Current upon 3rd fault	It displays the current when the latest fault occurs.
P9-19	Bus voltage upon 3rd fault	It displays the bus voltage when the latest fault occurs.

Function Code	Parameter Name	Description																				
P9-20	DI status upon 3rd fault	<p>It displays the status of all DI terminals when the latest fault occurs.</p> <p>The sequence is as follows:</p> <table border="1" style="margin-left: 20px;"> <tr> <td>BIT9</td><td>BIT8</td><td>BIT7</td><td>BIT6</td><td>BIT5</td><td>BIT4</td><td>BIT3</td><td>BIT2</td><td>BIT1</td><td>BIT0</td> </tr> <tr> <td>D10</td><td>D19</td><td>D18</td><td>D17</td><td>D16</td><td>D15</td><td>D14</td><td>D13</td><td>D12</td><td>D11</td> </tr> </table> <p>If a DI is ON, the setting is 1. If the DI is OFF, the setting is 0. The value is the equivalent decimal number converted from the DI status..</p>	BIT9	BIT8	BIT7	BIT6	BIT5	BIT4	BIT3	BIT2	BIT1	BIT0	D10	D19	D18	D17	D16	D15	D14	D13	D12	D11
BIT9	BIT8	BIT7	BIT6	BIT5	BIT4	BIT3	BIT2	BIT1	BIT0													
D10	D19	D18	D17	D16	D15	D14	D13	D12	D11													
P9-21	Output terminal status upon 3rd fault	<p>It displays the status of all output terminals when the latest fault occurs.</p> <p>The sequence is as follows:</p> <table border="1" style="margin-left: 20px;"> <tr> <td>BIT4</td><td>BIT3</td><td>BIT2</td><td>BIT1</td><td>BIT0</td> </tr> <tr> <td>DO2</td><td>DO1</td><td>REL2</td><td>REL1</td><td>FMP</td> </tr> </table> <p>If an output terminal is ON, the setting is 1. If the output terminal is OFF, the setting is 0. The value is the equivalent decimal number converted from the DI statuses.</p>	BIT4	BIT3	BIT2	BIT1	BIT0	DO2	DO1	REL2	REL1	FMP										
BIT4	BIT3	BIT2	BIT1	BIT0																		
DO2	DO1	REL2	REL1	FMP																		
P9-22	Inverter status upon 3rd fault	Reserved																				
P9-23	Power-on time upon 3rd fault	It displays the present power-on time when the latest fault occurs.																				
P9-24	Running time upon 3rd fault	It displays the present running time when the latest fault occurs.																				
P9-27	Frequency upon 2nd fault	Same as P9-17–P9-24.																				
P9-28	Current upon 2nd fault																					
P9-29	Bus voltage upon 2nd fault																					
P9-30	DI status upon 2nd fault																					
P9-31	Output terminal status upon 2nd fault																					
P9-32	Frequency upon 2nd fault																					
P9-33	Current upon 2nd fault																					
P9-34	Bus voltage upon 2nd fault																					
P9-37	DI status upon 1st fault		Same as P9-17–P9-24.																			
P9-38	Output terminal status upon 1st fault																					
P9-39	Frequency upon 1st fault																					
P9-40	Current upon 1st fault																					
P9-41	Bus voltage upon 3rd fault																					
P9-42	DI status upon 1st fault																					
P9-43	Output terminal status upon 1st fault																					
P9-44	Frequency upon 1st fault																					

Function Code	Parameter Name	Setting Range	Default
P9-47	Fault protection action selection 1	Unit's digit (Motor overload, Err11)	00000
		0: Coast to stop 1: Stop according to the stop mode 2: Continue to run	
		Ten's digit (Power input phase loss, Err12)	
		Same as unit's digit	
		Hundred's digit (Power output phase loss, Err13)	
		Same as unit's digit	
		Thousand's digit (External equipment fault, Err15)	
		Same as unit's digit	
		Ten thousand's digit (Communication fault, Err16)	
		Same as unit's digit	
P9-48	Fault protection action selection 2	Unit's digit (Encoder fault, Err20)	00000
		0: Coast to stop 1: Switch over to V/F control, stop according to the stop mode 2: Switch over to V/F control, continue to run	
		Ten's digit (EEPROM read-write fault, Err21)	
		0: Coast to stop 1: Stop according to the stop mode	
		Hundred's digit: reserved	
		Thousand's digit (Motor overheat, Err25)	
		Same as unit's digit in P9-47	
		Ten thousand's digit (Accumulative running time reached)	
		Same as unit's digit in P9-47	

Function Code	Parameter Name	Setting Range	Default
P9-49	Fault protection action selection 3	Unit's digit (User-defined fault 1, Err27)	00000
		Same as unit's digit in P9-47	
		Ten's digit (User-defined fault 2, Err28)	
		Same as unit's digit in P9-47	
		Hundred's digit (Accumulative power-on time reached, Err29)	
		Same as unit's digit in P9-47	
		Thousand's digit (Load becoming 0, Err30)	
		0: Coast to stop 1: Stop according to the stop mode 2: Continue to run at 7% of rated motor frequency and resume to the set frequency if the load recovers	
		Ten thousand's digit (PID feedback lost during running, Err31)	
		Same as unit's digit in P9-47	
P9-50	Fault protection action selection 4	Unit's digit (Too large speed deviation, Err42)	00000
		Same as unit's digit in P9-47	
		Ten's digit (Motor over-speed, Err43)	
		Same as unit's digit in P9-47	
		Hundred's digit (Initial position fault, Err51)	
		Same as unit's digit in P9-47	
		Thousand's digit (Speed feedback fault, Err52)	
		Same as unit's digit in P9-47	
		Ten thousand's digit: Reserved	

If "Coast to stop" is selected, the Inverter displays Err** and directly stops.

- If "Stop according to the stop mode" is selected, the Inverter displays A** and stops according to the stop mode. After stop, the Inverter displays Err**.
- If "Continue to run" is selected, the Inverter continues to run and displays A**. The running frequency is set in P9-54.

Function Code	Parameter Name	Setting Range	Default
P9-54	Frequency selection for continuing to run upon fault	0: Current running frequency 1: Set frequency 2: Frequency upper limit 3: Frequency lower limit 4: Backup frequency upon abnormality	0
P9-55	Backup frequency upon abnormality	0.0%–100.0% (maximum frequency)	100.0%

If a fault occurs during the running of the Inverter and the handling of fault is set to "Continue to run", the Inverter displays A** and continues to run at the frequency set in P9-54.

The setting of P9-55 is a percentage relative to the maximum frequency.

Function Code	Parameter Name	Setting Range	Default
P9-56	Type of motor temperature sensor	0: No temperature sensor 1: PT100 2: PT1000	0
P9-57	Motor overheat protection threshold	0–200°C	110°C
P9-58	Motor overheat warning threshold	0–200°C	90°C

If the motor temperature exceeds the value set in P9-57, the Inverter reports an alarm and acts according to the selected fault protection action.

If the motor temperature exceeds the value set in P9-58, the DO terminal on the Inverter allocated with function 39 (Motor overheat warning) becomes ON.

Function Code	Parameter Name	Setting Range	Default
P9-59	Action selection at instantaneous power failure	0: Invalid 1: Decelerate 2: Decelerate to stop	0
P9-60	Action pause judging voltage at instantaneous power failure	80.0%–100.0%	90.0%
P9-61	Voltage rally judging time at instantaneous power failure	0.00–100.00s	0.50s
P9-62	Action judging voltage at instantaneous power failure	60.0%–100.0% (standard bus voltage)	80.0%

Upon instantaneous power failure or sudden voltage dip, the DC bus voltage of the Inverter reduces. This function enables the Inverter to compensate the DC bus voltage reduction with the load feedback energy by reducing the output frequency so as to keep the Inverter running continuously.

- If P9-59 = 1, upon instantaneous power failure or sudden voltage dip, the Inverter decelerates. Once the bus voltage resumes to normal, the Inverter accelerates to the set frequency. If the bus voltage remains normal for the time exceeding the value set in P9-61, it is considered that the bus voltage resumes to normal.
- If P9-59 = 2, upon instantaneous power failure or sudden voltage dip, the Inverter decelerates to stop.

Figure 6-26 Inverter action diagram upon instantaneous power failure

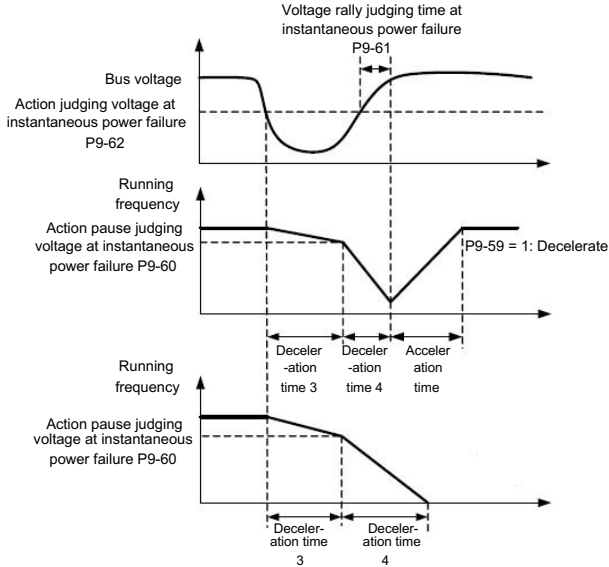

Function Code	Parameter Name	Setting Range	Default
P9-63	Protection upon load becoming 0	0: Disabled 1: Enabled	0
P9-64	Detection level of load becoming 0	0.0%–100.0% (rated motor current)	10.0%
P9-65	Detection time of load becoming 0	0.0–60.0s	1.0s

If protection upon load becoming 0 is enabled, when the output current of the Inverter is lower than the detection level (P9- 64) and the lasting time exceeds the detection time (P9-65), the output frequency of the Inverter automatically declines to 7% of the rated frequency. During the protection, the Inverter automatically accelerates to the set frequency if the load resumes to normal.

Function Code	Parameter Name	Setting Range	Default
P9-67	Over-speed detection value	0.0%–50.0% (maximum frequency)	20.0%
P9-68	Over-speed detection time	0.0–60.0s	1.0s

This function is valid only when the Inverter runs in the CLVC mode.

If the actual motor rotational speed detected by the Inverter exceeds the maximum frequency and the excessive value is greater than the value of P9-67 and the lasting time exceeds the value of P9-68, the Inverter reports Err43 and acts according to the selected fault protection action.

If the over-speed detection time is 0.0s, the over-speed detection function is disabled.

Function Code	Parameter Name	Setting Range	Default
P9-69	Detection value of too large speed deviation	0.0%–50.0% (maximum frequency)	20.0%
P9-70	Detection time of too large speed deviation	0.0–60.0s	5.0s

This function is valid only when the Inverter runs in the CLVC mode.

If the Inverter detects the deviation between the actual motor rotational speed detected by the Inverter and the set frequency is greater than the value of F9-69 and the lasting time exceeds the value of P9-70, the Inverter reports Err42 and according to the selected fault protection action.

If P9-70 (Detection time of too large speed deviation) is 0.0s, this function is disabled.

Group PA: Process Control PID Function

PID control is a general process control method. By performing proportional, integral and differential operations on the difference between the feedback signal and the target signal, it adjusts the output frequency and constitutes a feedback system to stabilize the controlled counter around the target value.

It is applied to process control such as flow control, pressure control and temperature control. The following figure shows the principle block diagram of PID control.

Figure 6-27 Principle block diagram of PID control

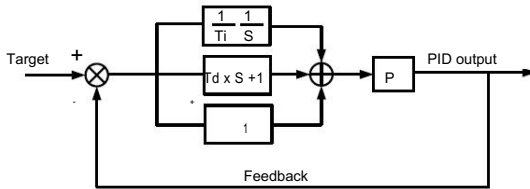

Function Code	Parameter Name	Setting Range	Default
PA-00	PID setting source	0: FA-01 1: AI1 2: AI2 3: AI3 4: Pulse setting (DI5) 5: Communication setting 6: Multi-reference	0
PA-01	PID digital setting	0.0%–100.0%	50.0%

PA-00 is used to select the channel of target process PID setting. The PID setting is a relative value and ranges from 0.0% to 100.0%. The PID feedback is also a relative value. The purpose of PID control is to make the PID setting and PID feedback equal.

Function Code	Parameter Name	Setting Range	Default
PA-02	PID feedback source	0: AI1 1: AI2 2: AI3 3: AI1 – AI2 4: Pulse setting (DI5) 5: Communication setting 6: AI1 + AI2 7: MAX (AI1 , AI2) 8: MIN (AI1 , AI2)	0

This parameter is used to select the feedback signal channel of process PID.

The PID feedback is a relative value and ranges from 0.0% to 100.0%.

Function Code	Parameter Name	Setting Range	Default
PA-03	PID action direction	0: Forward action 1: Reverse action	0

- 0: Forward action

When the feedback value is smaller than the PID setting, the Inverter's output frequency rises. For example, the winding tension control requires forward PID action.

- 1: Reverse action

When the feedback value is smaller than the PID setting, the Inverter's output frequency reduces. For example, the unwinding tension control requires reverse PID action.

Note that this function is influenced by the DI function 35 "Reverse PID action direction".

Function Code	Parameter Name	Setting Range	Default
PA-04	PID setting feedback range	0–65535	1000

This parameter is a non-dimensional unit. It is used for PID setting display (U0-15) and PID feedback display (U0-16).

Relative value 100% of PID setting feedback corresponds to the value of PA-04. If PA-04 is set to 2000 and PID setting is 100.0%, the PID setting display (U0-15) is 2000.

Function Code	Parameter Name	Setting Range	Default
PA-05	Proportional gain Kp1	0.0–100.0	20.0
PA-06	Integral time Ti1	0.01–10.00s	2.00s
PA-07	Differential time Td1	0.00–10.000	0.000s

- PA-05 (Proportional gain Kp1)

It decides the regulating intensity of the PID regulator. The higher the Kp1 is, the larger the regulating intensity is. The value 100.0 indicates when the deviation between PID feedback and PID setting is 100.0%, the adjustment amplitude of the PID regulator on the output frequency reference is the maximum frequency.

- PA-06 (Integral time T1)

It decides the integral regulating intensity. The shorter the integral time is, the larger the regulating intensity is. When the deviation between PID feedback and PID setting is 100.0%, the integral regulator performs continuous adjustment for the time set in FA-06. Then the adjustment amplitude reaches the maximum frequency.

- PA-07 (Differential time Td1)

It decides the regulating intensity of the PID regulator on the deviation change. The longer the differential time is, the larger the regulating intensity is. Differential time is the time within which the feedback value change reaches 100.0%, and then the adjustment amplitude reaches the maximum frequency.

Function Code	Parameter Name	Setting Range	Default
PA-08	Cut-off frequency of PID reverse rotation	0.00 to maximum frequency	2.00 Hz

In some situations, only when the PID output frequency is a negative value (Inverter reverse rotation), PID setting and PID feedback can be equal. However, too high reverse rotation frequency is prohibited in some applications, and PA-08 is used to determine the reverse rotation frequency upper limit.

Function Code	Parameter Name	Setting Range	Default
PA-09	PID deviation limit	0.0%–100.0%	0.0%

If the deviation between PID feedback and PID setting is smaller than the value of PA-09, PID control stops. The small deviation between PID feedback and PID setting will make the output frequency stabilize, effective for some closed-loop control applications.

Function Code	Parameter Name	Setting Range	Default
PA-10	PID differential limit	0.00%–100.00%	0.10%

It is used to set the PID differential output range. In PID control, the differential operation may easily cause system oscillation. Thus, the PID differential regulation is restricted to a small range.

Function Code	Parameter Name	Setting Range	Default
PA-11	PID setting change time	0.00–650.00s	0.00s

The PID setting change time indicates the time required for PID setting changing from 0.0% to 100.0%. The PID setting changes linearly according to the change time, reducing the impact caused by sudden setting change on the system.

Function Code	Parameter Name	Setting Range	Default
PA-12	PID feedback filter time	0.00–60.00s	0.00s
PA-13	PID output filter time	0.00–60.00s	0.00s

PA-12 is used to filter the PID feedback, helping to reduce interference on the feedback but slowing the response of the process closed-loop system.

PA-13 is used to filter the PID output frequency, helping to weaken sudden change of the Inverter output frequency but slowing the response of the process closed-loop system.

Function Code	Parameter Name	Setting Range	Default
PA-15	Proportional gain Kp2	0.0–100.0	20.0
PA-16	Integral time Ti2	0.01–10.00s	2.00s
PA-17	Differential time Td2	0.000–10.000s	0.000s
PA-18	PID parameter switchover condition	0: No switchover 1: Switchover via DI 2: Automatic switchover based on deviation	0
PA-19	PID parameter switchover deviation 1	0.0% to PA-20	20.0%
PA-20	PID parameter switchover deviation 2	PA-19 to 100.0%	80.0%

In some applications, PID parameters switchover is required when one group of PID parameters cannot satisfy the requirement of the whole running process.

These parameters are used for switchover between two groups of PID parameters. Regulator parameters PA-15 to PA-17 are set in the same way as PA-05 to PA-07.

The switchover can be implemented either via a DI terminal or automatically implemented based on the deviation.

If you select switchover via a DI terminal, the DI must be allocated with function 43 "PID parameter switchover". If the DI is OFF, group 1 (PA-05 to PA-07) is selected. If the DI is ON, group 2 (PA-15 to PA-17) is selected.

If you select automatic switchover, when the absolute value of the deviation between PID feedback and PID setting is smaller than the value of PA-19, group 1 is selected. When the absolute value of the deviation between PID feedback and PID setting is higher than the value of PA-20, group 2 is selected. When the deviation is between PA-19 and PA-20, the PID parameters are the linear interpolated value of the two groups of parameter values.

Figure 6-28 PID parameters switchover

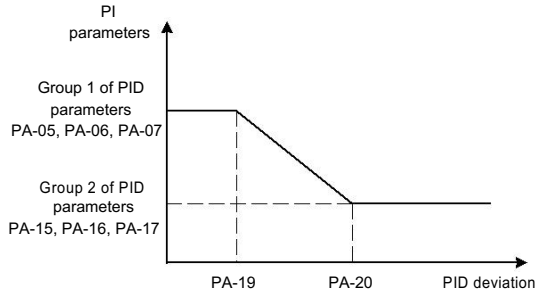

Function Code	Parameter Name	Setting Range	Default
PA-21	PID initial value	0.0%–100.0%	0.0%
PA-22	PID initial value holding time	0.00–650.00s	0.00s

When the Inverter starts up, the PID starts closed-loop algorithm only after the PID output is fixed to the PID initial value (PA-21) and lasts the time set in PA-22.

Figure 6-29 PID initial value function

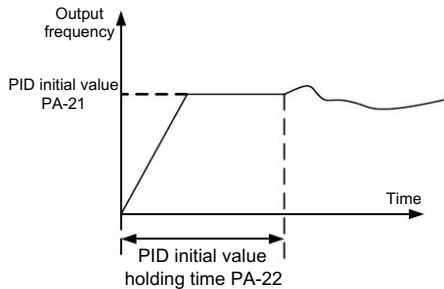

Function Code	Parameter Name	Setting Range	Default
PA-23	Maximum deviation between two PID outputs in forward direction	0.00%–100.00%	1.00%
PA-24	Maximum deviation between two PID outputs in reverse direction	0.00%–100.00%	1.00%

This function is used to limit the deviation between two PID outputs (2 ms per PID output) to suppress the rapid change of PID output and stabilize the running of the Inverter.

PA-23 and PA-24 respectively correspond to the maximum absolute value of the output deviation in forward direction and in reverse direction.

Function Code	Parameter Name	Setting Range	Default
PA-25	PID integral property	Unit's digit (Integral separated)	00
		0: Invalid	
		1: Valid	
		Ten's digit (Whether to stop integral operation when the output reaches the limit)	
		0: Continue integral operation	
		1: Stop integral operation	

- Integral separated

If it is set to valid, , the PID integral operation stops when the DI allocated with function 38 "PID integral pause" is ON In this case, only proportional and differential operations take effect.

If it is set to invalid, integral separated remains invalid no matter whether the DI allocated with function 38 "PID integral pause" is ON or not.

- Whether to stop integral operation when the output reaches the limit

If "Stop integral operation" is selected, the PID integral operation stops, which may help to reduce the PID overshoot.

Function Code	Parameter Name	Setting Range	Default
PA-26	Detection value of PID feedback loss	0.0%: Not judging feedback loss 0.1%–100.0%	0.0%
PA-27	Detection time of PID feedback loss	0.0–20.0s	0.0s

These parameters are used to judge whether PID feedback is lost.

If the PID feedback is smaller than the value of PA-26 and the lasting time exceeds the value of PA-27, the Inverter reports Err31 and acts according to the selected fault protection action.

Function Code	Parameter Name	Setting Range	Default
PA-28	PID operation at stop	0: No PID operation at stop 1: PID operation at stop	0

It is used to select whether to continue PID operation in the state of stop. Generally, the PID operation stops when the Inverter stops.

Group PB: Swing Frequency, Fixed Length and Count

The swing frequency function is applied to the textile and chemical fiber fields and the applications where traversing and winding functions are required.

The swing frequency function indicates that the output frequency of the Inverter swings up and down with the set frequency as the center. The trace of running frequency at the time axis is shown in the following figure.

The swing amplitude is set in PB-00 and PB-01. When PB-01 is set to 0, the swing amplitude is 0 and the swing frequency does not take effect.

Figure 6-30 Swing frequency control

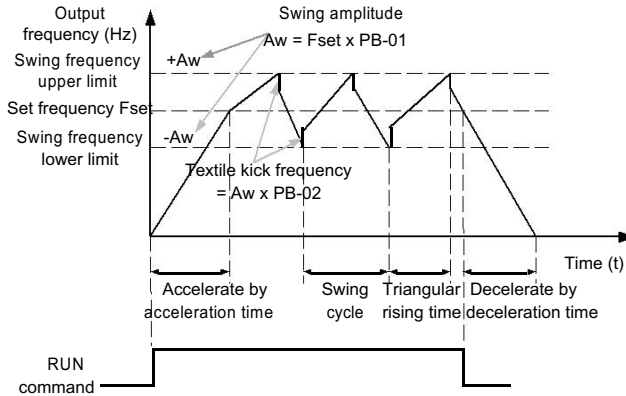

Function Code	Parameter Name	Setting Range	Default
PB-00	Swing frequency setting mode	0: Relative to the central frequency 1: Relative to the maximum frequency	0

This parameter is used to select the base value of the swing amplitude.

- 0: Relative to the central frequency (P0-07 frequency source selection)
It is variable swing amplitude system. The swing amplitude varies with the central frequency (set frequency).
- 1: Relative to the maximum frequency (P0-10 maximum output frequency)
It is fixed swing amplitude system. The swing amplitude is fixed.

Function Code	Parameter Name	Setting Range	Default
PB-01	Swing frequency amplitude	0.0%–100.0%	0.0%
PB-02	Jump frequency amplitude	0.0%–50.0%	0.0%

This parameter is used to determine the swing amplitude and jump frequency amplitude. The swing frequency is limited by the frequency upper limit and frequency lower limit.

- If relative to the central frequency (PB-00 = 0), the actual swing amplitude AW is the calculation result of P0-07 (Frequency source selection) multiplied by PB-01.
- If relative to the maximum frequency (PB-00 = 1), the actual swing amplitude AW is the calculation result of P0-10 (Maximum frequency) multiplied by PB-01.

Jump frequency = Swing amplitude AW x PB-02 (Jump frequency amplitude).

- If relative to the central frequency (PB-00 = 0), the jump frequency is a variable value.
- If relative to the maximum frequency (PB-00 = 1), the jump frequency is a fixed value.

The swing frequency is limited by the frequency upper limit and frequency lower limit.

Function Code	Parameter Name	Setting Range	Default
PB-03	Swing frequency cycle	0.0–3000.0s	10.0s
PB-04	Triangular wave rising time coefficient	0.0%–100.0%	50.0%

PB-03 specifies the time of a complete swing frequency cycle.

PB-04 specifies the time percentage of triangular wave rising time to PB-03 (Swing frequency cycle).

- Triangular wave rising time = PB-03 (Swing frequency cycle) x PB-04 (Triangular wave rising time coefficient, unit: s)
- Triangular wave falling time = PB-03 (Swing frequency cycle) x (1 – PB-04 Triangular wave rising time coefficient , unit: s)

Function Code	Parameter Name	Setting Range	Default
PB-05	Set length	0–65535 m	1000 m
PB-06	Actual length	0–65535 m	0 m
PB-07	Number of pulses per meter	0.1–6553.5	100.0

The preceding parameters are used for fixed length control.

The length information is collected by DI terminals. PB-06 (Actual length) is calculated by dividing the number of pulses collected by the DI terminal by PB-07 (Number of pulses each meter).

When the actual length PB-06 exceeds the set length in PB-05, the DO terminal allocated with function 10 (Length reached) becomes ON.

During the fixed length control, the length reset operation can be performed via the DI terminal allocated with function 28. For details, see the descriptions of P4-00 to P4-09.

Allocate corresponding DI terminal with function 27 (Length count input) in applications. If the pulse frequency is high, DI5 must be used.

Function Code	Parameter Name	Setting Range	Default
PB-08	Set count value	1–65535	1000
PB-09	Designated count value	1–65535	1000

The count value needs to be collected by DI terminal. Allocate the corresponding DI terminal with function 25 (Counter input) in applications. If the pulse frequency is high, DI5 must be used.

When the count value reaches the set count value (PB-08), the DO terminal allocated with function 8 (Set count value reached) becomes ON. Then the counter stops counting.

When the counting value reaches the designated counting value (PB-09), the DO terminal allocated with function 9 (Designated count value reached) becomes ON. Then the counter continues to count until the set count value is reached.

PB-09 should be equal to or smaller than PB-08.

Figure 6-31 Reaching the set count value and designated count value

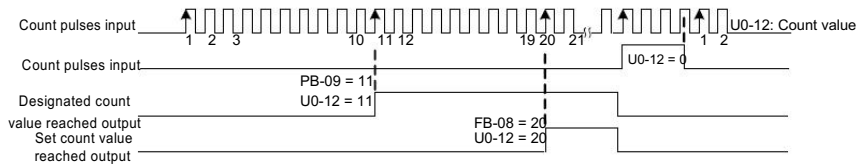

Group PC: Multi-Reference and Simple PLC Function

The SU200 multi-reference has many functions. Besides multi-speed, it can be used as the setting source of the V/F separated voltage source and setting source of process PID. In addition, the multi-reference is relative value.

The simple PLC function is different from the SU200 user programmable function. Simple PLC can only complete simple combination of multi-reference, while the user programmable function is more practical. For details, see the descriptions of group A7.

Function Code	Parameter Name	Setting Range	Default
PC-00	Reference 0	-100.0%–100.0%	0.0%
PC-01	Reference 1	-100.0%–100.0%	0.0%
PC-02	Reference 2	-100.0%–100.0%	0.0%
PC-03	Reference 3	-100.0%–100.0%	0.0%
PC-04	Reference 4	-100.0%–100.0%	0.0%
PC-05	Reference 5	-100.0%–100.0%	0.0%
PC-06	Reference 6	-100.0%–100.0%	0.0%
PC-07	Reference 7	-100.0%–100.0%	0.0%
PC-08	Reference 8	-100.0%–100.0%	0.0%
PC-09	Reference 9	-100.0%–100.0%	0.0%
PC-10	Reference 10	-100.0%–100.0%	0.0%
PC-11	Reference 11	-100.0%–100.0%	0.0%
PC-12	Reference 12	-100.0%–100.0%	0.0%
PC-13	Reference 13	-100.0%–100.0%	0.0%
PC-14	Reference 14	-100.0%–100.0%	0.0%
PC-15	Reference 15	-100.0%–100.0%	0.0%

Multi-reference can be the setting source of frequency, V/F separated voltage and process PID. The multi-reference is relative value and ranges from -100.0% to 100.0%.

As frequency source, it is a percentage relative to the maximum frequency. As V/F separated voltage source, it is a percentage relative to the rated motor voltage. As process PID setting source, it does not require conversion.

Multi-reference can be switched over based on different states of DI terminals. For details, see the descriptions of group P4.

Function Code	Parameter Name	Setting Range	Default
PC-16	Simple PLC running mode	0: Stop after the Inverter runs one cycle 1: Keep final values after the Inverter runs one cycle 2: Repeat after the Inverter runs one cycle	0

- 0: Stop after the Inverter runs one cycle

The Inverter stops after running one cycle, and will not start up until receiving another command.

- 1: Keep final values after the Inverter runs one cycle

The Inverter keeps the final running frequency and direction after running one cycle.

- 2: Repeat after the Inverter runs one cycle

The Inverter automatically starts another cycle after running one cycle, and will not stop until receiving the stop command.

Simple PLC can be either the frequency source or V/F separated voltage source.

When simple PLC is used as the frequency source, whether parameter values of PC-00 to PC-15 are positive or negative determines the running direction. If the parameter values are negative, it indicates that the Inverter runs in reverse direction.

Figure 6-32 Simple PLC when used as frequency source

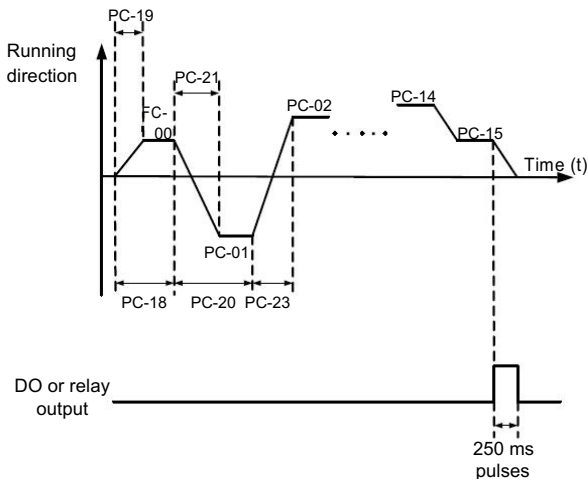

Function Code	Parameter Name	Setting Range	Default
PC-17	Simple PLC retentive selection	Unit's digit (Retentive upon power failure) 0: No 1: Yes	00
		Ten's digit (Retentive upon stop) 0: No 1: Yes	

PLC retentive upon power failure indicates that the Inverter memorizes the PLC running moment and running frequency before power failure and will continue to run from the memorized moment after it is powered on again. If the unit's digit is set to 0, the Inverter restarts the PLC process after it is powered on again.

PLC retentive upon stop indicates that the Inverter records the PLC running moment and running frequency upon stop and will continue to run from the recorded moment after it starts up again. If the ten's digit is set to 0, the Inverter restarts the PLC process after it starts up again.

Function Code	Parameter Name	Setting Range	Default
PC-18	Running time of simple PLC reference 0	0.0–6553.5s (h)	0.0s (h)
PC-19	Acceleration/deceleration time of simple PLC reference 0	0–3	0
PC-20	Running time of simple PLC reference 1	0.0–6553.5s (h)	0.0s (h)
PC-21	Acceleration/deceleration time of simple PLC reference 1	0–3	0
PC-22	Running time of simple PLC reference 2	0.0–6553.5s (h)	0.0s (h)
PC-23	Acceleration/deceleration time of simple PLC reference 2	0–3	0
PC-24	Running time of simple PLC reference 3	0.0–6553.5s (h)	0.0s (h)
PC-25	Acceleration/deceleration time of simple PLC reference 3	0–3	0
PC-26	Running time of simple PLC reference 4	0.0–6553.5s (h)	0.0s (h)
PC-27	Acceleration/deceleration time of simple PLC reference 4	0–3	0
PC-28	Running time of simple PLC reference 5	0.0–6553.5s (h)	0.0s (h)
PC-29	Acceleration/deceleration time of simple PLC reference 5	0–3	0
PC-30	Running time of simple PLC reference 6	0.0–6553.5s (h)	0.0s (h)
PC-31	Acceleration/deceleration time of simple PLC reference 6	0–3	0
PC-32	Running time of simple PLC reference 7	0.0–6553.5s (h)	0.0s (h)
PC-33	Acceleration/deceleration time of simple PLC reference 7	0–3	0

Function Code	Parameter Name	Setting Range	Default
PC-34	Running time of simple PLC reference 8	0.0–6553.5s (h)	0.0s (h)
PC-35	Acceleration/deceleration time of simple PLC reference 8	0–3	0
PC-36	Running time of simple PLC reference 9	0.0–6553.5s (h)	0.0s (h)
PC-37	Acceleration/deceleration time of simple PLC reference 9	0–3	0
PC-38	Running time of simple PLC reference 10	0.0–6553.5s (h)	0.0s (h)
PC-39	Acceleration/deceleration time of simple PLC reference 10	0–3	0
PC-40	Running time of simple PLC reference 11	0.0–6553.5s (h)	0.0s (h)
PC-41	Acceleration/deceleration time of simple PLC reference 11	0–3	0
PC-42	Running time of simple PLC reference 12	0.0–6553.5s (h)	0.0s (h)
PC-43	Acceleration/deceleration time of simple PLC reference 12	0–3	0
PC-44	Running time of simple PLC reference 13	0.0–6553.5s (h)	0.0s (h)
PC-45	Acceleration/deceleration time of simple PLC reference 13	0–3	0
PC-46	Running time of simple PLC reference 14	0.0–6553.5s (h)	0.0s (h)
PC-47	Acceleration/deceleration time of simple PLC reference 14	0–3	0
PC-48	Running time of simple PLC reference 15	0.0–6553.5s (h)	0.0s (h)
PC-49	Acceleration/deceleration time of simple PLC reference 15	0–3	0
PC-50	Time unit of simple PLC running	0: s (second) 1: h (hour)	0

Function Code	Parameter Name	Setting Range	Default
PC-51	Reference 0 source	0: Set by PC-00 1: AI1 2: AI2 3: Keypad potentiometer 4: Pulse setting 5: PID 6: Set by preset frequency (P0-08), modified via terminal UP/DOWN	0

It determines the setting channel of reference 0. You can perform convenient switchover between the setting channels. When multi-reference or simple PLC is used as frequency source, the switchover between two frequency sources can be realized easily.

Group PD: Communication parameters

Please refer to <SU200 communication protocol>

Group PP: User Password

Function Code	Parameter Name	Setting Range	Default
PP-00	User password	0-65535	0

If it is set to any non-zero number, the password protection function is enabled. After a password has been set and taken effect, you must enter the correct password in order to enter the menu. If the entered password is incorrect you cannot view or modify parameters.

If PP-00 is set to 00000, the previously set user password is cleared, and the password protection function is disabled.

Function Code	Parameter Name	Setting Range	Default
PP-01	Restore default settings	0: No operation 1: Restore factory settings except motor parameters 2: Clear records 4: Restore user backup parameters 501: Back up current user parameters	0

- 1: Restore default settings except motor parameters

If PP-01 is set to 1, most function codes are restored to the default settings except motor parameters, frequency reference resolution (P0-22), fault records, accumulative running time (P7-09), accumulative power-on time (P7-13) and accumulative power consumption (P7-14).

- 2: Clear records

If PP-01 is set to 2, the fault records, accumulative running time (P7-09), accumulative power-on time (P7-13) and accumulative power consumption (P7-14) are cleared.

Group U0: Monitoring Parameters

Group U0 is used to monitor the Inverter's running state. You can view the parameter values by using operation panel, convenient for on-site commissioning, or from the host computer by means of communication (address: 0x7000-0x7044).

U0-00 to U0-31 are the monitoring parameters in the running and stop state defined by P7-03 and P7-04. For more details, see below:

Function Code	Parameter Name	Display Range
U0-00	Running frequency	0.00–320.00 Hz (F0-22 = 2)
U0-01	Set frequency	0.00–3200.0 Hz (F0-22 = 1)

These two parameters display the absolute value of theoretical running frequency and set frequency. For the actual output frequency of the Inverter, see U0-19.

Function Code	Parameter Name	Display Range
U0-02	Bus voltage	0.0–3000.0 V

It displays the Inverter's bus voltage.

Function Code	Parameter Name	Display Range
U0-03	Output voltage	0–1140 V

It displays the Inverter's output voltage in the running state.

Function Code	Parameter Name	Display Range
U0-04	Output current	0.00–655.35 A (Inverter power ≤ 55 kW) 0.0–6553.5 A (Inverter power > 55 kW)

It displays the Inverter's output current in the running state.

Function Code	Name	Display Range
U0-05	Output power	0–32767

It displays the Inverter's output power in the running state.

Function Code	Parameter Name	Display Range
U0-06	Output torque	-200.0%–200.0%

It displays the Inverter's output torque in the running state.

Function Code	Parameter Name	Display Range
U0-07	DI state	0–32767

It displays the current state of DI terminals. After the value is converted into a binary number, each bit corresponds to a DI. "1" indicates high level signal, and "0" indicates low level signal. The corresponding relationship between bits and DIs is described in the following table.

Bit0	Bit1	Bit2	Bit3	Bit4	Bit5	Bit6	Bit7	Bit8	Bit9
DI1	DI2	DI3	DI4	DI5	DI6	DI7	DI8	DI9	DI10
Bit10	Bit11	Bit12	Bit13	Bit10	Bit11	Bit12	Bit13	Bit14	Bit15
VDI1	VDI2	VDI3	VDI4	VDI1	VDI2	VDI3	VDI4	VDI5	

Function Code	Parameter Name	Display Range
U0-08	DO state	0-1023

It indicates the current state of DO terminals. After the value is converted into a binary number, each bit corresponds to a DO. "1" indicates high level signal, and "0" indicates low level signal. The corresponding relationship between bits and DOs is described in the following table.

Table 6-15 Corresponding relationship between bits and DOs

Bit0	Bit1	Bit2	Bit3	Bit4	Bit5
DO3	Relay 1	Relay 2	DO1	DO2	VDO1
Bit6	Bit7	Bit8	Bit9	Bit10	Bit11
VDO2	VDO3	VDO4	VDO5		

Function Code	Parameter Name	Display Range
U0-18	Input pulse frequency	0.00–100.00 kHz

It displays the high-speed pulse sampled frequency of DI5, in minimum unit of 0.01 kHz.

Function Code	Parameter Name	Display Range
U0-19	Feedback speed	-320.00–320.00 Hz -3200.0–3200.0 Hz

It displays the actual output frequency of the Inverter.

- If P0-22 (Frequency reference resolution) is set to 1, the display range is -3200.00–3200.00 Hz.
- If P0-22 (Frequency reference resolution) is set to 2, the display range is -320.00Hz–320.00 Hz.

Function Code	Parameter Name	Display Range
U0-20	Remaining running time	0.0–6500.0 min

It displays the remaining running time when the timing operation is enabled. For details on timing operation, refer to P8-42 to P8-44.

Function Code	Parameter Name	Display Range
U0-21	AI1 voltage before correction	0.00–10.57 V
U0-22	AI2 voltage (V)/ current (mA) before correction	0.00–10.57 V 0.00–20.00 mA
U0-23	AI3 voltage before correction	-10.57–10.57 V

They display the AI sampling voltage/current value of AI. The actually used voltage/current is obtained after linear correction to reduce the deviation between the sampled voltage/current and the actual input voltage/current.

Function Code	Parameter Name	Display Range
U0-24	Linear speed	0-65535 m/min

It displays the linear speed of the DI5 high-speed pulse sampling. The unit is meter/minute.

The linear speed is obtained according to the actual number of pulses sampled per minute and PB-07 (Number of pulses per meter).

Function Code	Parameter Name	Display Range
U0-27	Pulse input frequency	0-65535 Hz

It displays the DI5 high-speed pulse sampling frequency, in minimum unit of 1 Hz. It is the same as U0-18, except for the difference in units.

Function Code	Parameter Name	Display Range
U0-28	Communication setting value	-100.00%-100.00%

It displays the data written by means of the communication address 0x1000.

Function Code	Parameter Name	Display Range
U0-29	Encoder feedback speed	-320.00-320.00 Hz -3200.0-3200.0 Hz

It displays the motor running frequency measured by the encoder.

- If P0-22 (Frequency reference resolution) is 1, the display range is -3200.0-3200.0 Hz.
- If P0-22 (Frequency reference resolution) is 2, the display range is -320.00-320.00 Hz.

Function Code	Name	Display Range
U0-30	Main frequency X	0.00-320.00 Hz 0.0-3200.0 Hz

It displays the setting of main frequency X.

- If P0-22 (Frequency reference resolution) is 1, the display range is -3200.0-3200.0 Hz.
- If P0-22 (Frequency reference resolution) is 2, the display range is -320.00-320.00 Hz.

Function Code	Parameter Name	Display Range
U0-31	Auxiliary frequency Y	0.00-320.00 Hz 0.0-3200.0 Hz

It displays the setting of auxiliary frequency Y.

- If P0-22 (frequency reference resolution) is 1, the display range is -3200.0–3200.0 Hz.
- If P0-22 (frequency reference resolution) is 2, the display range is -320.00–320.00 Hz.

Function Code	Parameter Name	Display Range
U0-33	Synchronous motor rotor position	0.0°–359.9°

It displays the rotor position of the synchronous motor.

Function Code	Parameter Name	Display Range
U0-34	Motor temperature	0–200 °C

It displays the motor temperature obtained by means of AI3 sampling. For the motor temperature detection, see P9-56.

Function Code	Parameter Name	Display Range
U0-35	Target torque	-200.0%–200.0%

It displays the current torque upper limit.

Function Code	Parameter Name	Display Range
U0-36	Resolver position	0–4095

It displays the current resolver position.

Function Code	Parameter Name	Display Range
U0-37	Power factor angle	-

It displays the current power factor angle.

Function Code	Parameter Name	Display Range
U0-38	ABZ position	0–65535

It displays the phase A and B pulse counting of the current ABZ or UVW encoder. This value is four times the number of pulses that the encoder runs. For example, if the display is 4000, the actual number of pulses that the encoder runs is $4000/4 = 1000$.

The value increase when the encoder rotates in forward direction and decreases when the encoder rotates in reverse direction. After increasing to 65535, the value starts to increase from 0 again. After decreasing to 0, the value starts to decrease from 65535 again.

You can check whether the installation of the encoder is normal by viewing U0-38.

Function Code	Parameter Name	Display Range
U0-39	Target voltage upon V/F separation	0 V to rated motor voltage
U0-40	Output voltage upon V/F separation	0 V to rated motor voltage

They display the target output voltage and current actual output voltage in the V/F separation state. For V/F separation, see the descriptions of group P3.

Function Code	Parameter Name	Display Range
U0-41	DI state visual display	-

Function Code	Parameter Name	Display Range
---------------	----------------	---------------

It displays the DI state visually and the display format is shown in the following figure.

Figure 6-34 Display format of the DI state

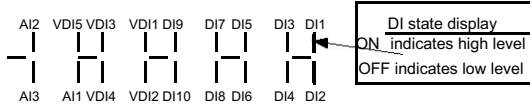

Function Code	Parameter Name	Display Range
U0-42	DO state visual display	-

It displays the DO state visually and the display format is shown in the following figure.

Figure 6-35 Display format of the DO state

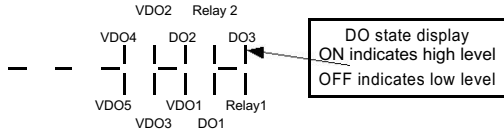

Function Code	Parameter Name	Display Range
U0-43	DI function state visual display 1	-

It displays whether the DI functions 1-40 are valid. The operation panel has five 7-segment LEDs and each 7-segment LED displays the selection of eight functions. The 7-segment LED is defined in the following figure.

Figure 6-36 Definition of 7-segment LED

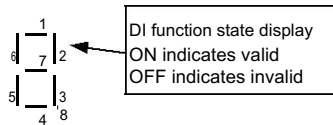

The 7-segment LED display functions 1-8, 9-16, 17-24, 25-32 and 33-40 respectively from right to left.

Function Code	Parameter Name	Display Range
U0-44	DI function state visual display 2	-

It displays whether the DI functions 41-59 are valid. The display format is similar to U0-43. The 7-segment LEDs display functions 41-48, 49-56 and 57-59, respectively from right to left.

U0-58		Phase Z counting	0-65535
-------	--	------------------	---------

It displays the phase Z counting of the current ABZ or UVW encoder. The value increases or decreases by 1 every time the encoder rotates one revolution forwardly or reversely.

You can check whether the installation of the encoder is normal by viewing U0-58. It displays the current set frequency and running frequency. 100.00% corresponds to the Inverter's maximum frequency (P0-10).

It displays the running state of the Inverter. The data format is listed in the following table:

It displays the data at point-point communication. U0-63 is the data sent by the master, and U0-64 is the data received by the slave.

Function Code	Parameter Name	Display Range
U0-59	Current set frequency	-100.00%~100.00%
U0-60	Current running frequency	-100.00%~100.00%

Function Code	Parameter Name	Display Range
U0-61	Inverter running state	0-65535

U0-61	Bit0	0: Stop
	Bit1	1: Forward 2: Reverse
	Bit2	0: Constant
	Bit3	1: Accelerate 2: Decelerate
	Bit4	0: Bus voltage normal 1: Under voltage

Function Code	Name	Display Range
U0-62	Current fault code	0-99

It displays the current fault code.

Function Code	Name	Display Range
U0-63	Sent value of point-point communication	-100.00%~100.00%
U0-64	Received value of point-point communication	-100.00%~100.00%

Function Code	Name	Display Range	
U0-65	Torque upper limit	-200.00%~200.00%	

Chapter 9 EMC solution

9.1 Definition of Terms

EMC Electromagnetic compatibility (EMC) describes the ability of electronic and electrical devices or systems to work properly in the electromagnetic environment and not to generate electromagnetic interference that influences other local devices or systems.

In other words, EMC includes two aspects: The electromagnetic interference generated by a device or system must be restricted within a certain limit; the device or system must have sufficient immunity to the electromagnetic interference in the environment.

First environment

Environment that includes domestic premises, it also includes establishments directly connected without intermediate transformers to a low-voltage power supply network which supplies buildings used for domestic purposes

Second environment

Environment that includes all establishments other than those directly connected to a low-voltage power supply network which supplies buildings used for domestic purposes

Category C1 Inverter

Power Drive System (PDS) of rated voltage less than 1 000 V, intended for use in the first environment

Category C2 Inverter

PDS of rated voltage less than 1 000 V, which is neither a plug in device nor a movable device and, when used in the first environment, is intended to be installed and commissioned only by a professional

Category C3 Inverter

PDS of rated voltage less than 1 000 V, intended for use in the second environment and not intended for use in the first environment

Category C4 Inverter

PDS of rated voltage equal to or above 1 000 V, or rated current equal to or above 400 A, or intended for use in complex systems in the second environment

9.2 Introduction to EMC Standard

9.2.1 EMC Standard

The SU200 series Inverter satisfies the requirements of standard EN 61800- 3: 2004 Category C2. The Inverters are applied to both the first environment and the second environment.

9.2.2 Installation Environment

The system manufacturer using the Inverter is responsible for compliance of the system with the European EMC directive. Based on the application of the system, the integrator must ensure that the system complies with standard EN 61800-3: 2004 Category C2, C3 or C4.

The system (machinery or appliance) installed with the Inverter must also have the CE mark. The system integrator is responsible for compliance of the system with the EMC directive and standard EN 61800-3: 2004 Category C2.

9.3 Selection of Peripheral EMC Devices

Installation of EMC Input Filter on Power Input Side

An EMC filter installed between the Inverter and the power supply can not only restrict the interference of electromagnetic noise in the surrounding environment on the Inverter, but also prevents the interference from the Inverter on the surrounding equipment. The SU200 series Inverter satisfies the requirements of category C2 only with an EMC filter installed on the power input side. The installation precautions are as follows:
Strictly comply with the ratings when using the EMC filter. The EMC filter is category I electric apparatus, and therefore, the metal housing ground of the filter should be in good contact with the metal ground of the installation cabinet on a large area, and requires good conductive continuity. Otherwise, it will result in electric shock or poor EMC effect. The ground of the EMC filter and the PE conductor of the Inverter must be tied to the same common ground. Otherwise, the EMC effect will be affected seriously.

The EMC filter should be installed as closely as possible to the power input side of the Inverter.

9.3.2 Installation of AC Input Reactor on Power Input Side

An AC input reactor is installed to eliminate the harmonics of the input current. As an optional device, the reactor can be installed externally to meet strict requirements of an application environment for harmonics. The following table lists the recommended manufacturers and models of input reactors.

9.3.3 Installation of AC Output Reactor on Power Output Side

Whether to install an AC output reactor on the power output side is dependent on the actual situation. The cable connecting the Inverter and the motor should not be too long; capacitance enlarges when an over-long cable is used and thus high-harmonics current may be easily generated.

If the length of the output cable is equal to or greater than the value in the following table, install an AC output reactor on the power output side of the Inverter.

9.4 Solutions to Common EMC Interference Problems

The Inverter generates very strong interference. Although EMC measures are taken, the interference may still exist due to improper cabling or grounding during use. When the Inverter interferes with other devices, adopt the following solutions.

Interference Type	Solution
Leakage protection switch tripping	<ul style="list-style-type: none"> • Connect the motor housing to the PE of the Inverter. • Connect the PE of the Inverter to the PE of the mains power supply. • Add a safety capacitor to the power input cable. • Add magnetic rings to the input drive cable.
Inverter interference during running	<ul style="list-style-type: none"> • Connect the motor housing to the PE of the Inverter. • Connect the PE of the Inverter to the PE of the mains voltage. • Add a safety capacitor to the power input cable and wind the cable with magnetic rings. • Add a safety capacitor to the interfered signal port or wind the signal cable with magnetic rings. • Connect the equipment to the common ground.
Communication interference	<ul style="list-style-type: none"> • Connect the motor housing to the PE of the Inverter. • Connect the PE of the Inverter to the PE of the mains voltage. • Add a safety capacitor to the power input cable and wind the cable with magnetic rings. • Add a matching resistor between the communication cable source and the load side. • Add a common grounding cable besides the communication cable. • Use a shielded cable as the communication cable and connect the cable shield to the common grounding point.
I/O interference	<ul style="list-style-type: none"> • Enlarge the capacitance at the low-speed DI. A maximum of 0.11 μF capacitance is suggested. • Enlarge the capacitance at the AI. A maximum of 0.22 μF is suggested.

Chapter10 Maintenance and Troubleshooting

10.1 Routine Repair and Maintenance of the SU200

10.1.1 Routine Maintenance

The influence of the ambient temperature, humidity, dust and vibration will cause the aging of the devices in the Inverter, which may cause potential faults or reduce the service life of the Inverter. Therefore, it is necessary to carry out routine and periodic maintenance.

Routine maintenance involves checking:

Whether the motor sounds abnormally during running

Whether the motor vibrates excessively during running

Whether the installation environment of the Inverter changes.

Whether the Inverter's cooling fan works normally

Whether the Inverter overheats

Routine cleaning involves:

Keep the Inverter clean all the time.

Remove the dust, especially metal powder on the surface of the Inverter, to prevent the dust from entering the Inverter.

Clear the oil stain on the cooling fan of the Inverter.

10.1.2 Periodic Inspection

Perform periodic inspection in places where inspection is difficult.

Periodic inspection involves:

Check and clean the air duct periodically.

Check whether the screws become loose.

Check whether the Inverter is corroded.

Check whether the wiring terminals show signs of arcing;

Main circuit insulation test

Prompt

Before measuring the insulating resistance with megameter (500 VDC megameter recommended), disconnect the main circuit from the Inverter.

Do not use the insulating resistance meter to test the insulation of the control circuit. The high voltage test need not be performed again because it has been completed before delivery.

10.1.3 Replacement of Vulnerable Components

The vulnerable components of the Inverter are cooling fan and filter electrolytic capacitor. Their service life is related to the operating environment and maintenance status. Generally, the service life is shown as follows:

Component	Service Life	Possible Damage Reason	Judging Criteria
Fan	2 to 3 years	<ul style="list-style-type: none"> • Bearing worn • Blade aging 	<ul style="list-style-type: none"> • Whether there is crack on the blade • Whether there is abnormal vibration noise upon startup
Electrolytic capacitor	4 to 5 years	<ul style="list-style-type: none"> • Input power supply in poor quality • High ambient temperature • Frequent load jumping • Electrolytic aging 	<ul style="list-style-type: none"> • Whether there is liquid leakage. • Whether the safe valve has projected. • Measure the static capacitance. • Measure the insulating resistance.

10.1.4 Storage of the Inverter

For storage of the Inverter, pay attention to the following two aspects:

Pack the Inverter with the original packing box provided by Inovance.

Long-term storage degrades the electrolytic capacitor. Thus, the Inverter must be energized once every 2 years, each time lasting at least 5 hours. The input voltage must be increased slowly to the rated value with the regulator.

10.2 Warranty Agreement

Free warranty only applies to the Inverter itself.

We will provide 18-month warranty (starting from the leave-factory date as indicated on the barcode) for the failure or damage under normal use conditions. If the equipment has been used for over 18 months, reasonable repair expenses will be charged.

Reasonable repair expenses will be charged for the damages due to the following causes:

Improper operation without following the instructions

Fire, flood or abnormal voltage.

Using the Inverter for non-recommended function

10.3 Faults and Solutions

The SU200 provides a total of 51 pieces of fault information and protective functions. After a fault occurs, the Inverter implements the protection function, and displays the fault code on the operation panel (if the operation panel is available).

Before contacting us for technical support, you can first determine the fault type, analyze the causes, and perform troubleshooting according to the following tables. If the fault cannot be rectified, contact the agent or us.

10.4 Solutions to the faults of the SU200 inverter

Fault code	Fault description	Possible reason	Countermeasures
Inverter unit protection	Err01	1, The inverter output circuit short circuit 2, the motor and inverter wiring is too long 3, the module overheating 4. The inverter wiring is loose 5, The circuit board abnormal 6, inverter module exception	1, Excluding the external fault 2, Install the reactor or output filter 3, Check the air duct is blocked; 4, Plug all the cable 5, Seek technical support
Over current in acceleration	Err02	1, Motor to ground short circuit 2, Not perform auto tuning 3, The acceleration time is too short 4, Torque boost is not appropriate 5, The grid voltage is low 6, Loading suddenly in acceleration 7, The using Inverter capacity (rated power is small)	1, Excluding the external fault 2, Perform motor ID auto tuning 3, Increase the acceleration time 4, Adjust the torque boost or V / F curve 5, Adjust voltage of power supply to normal 6, Adjust the load 7, Select big power inverter instead
Over current in deceleration	Err03	1, Output short circuit or output to ground 2, No performance ID auto tuning for carrying vector control 3, The deceleration time is too short 4, The voltage is low 5, Loading suddenly when deceleration 6, No installing of brake unit and brake resistor	1, Excluding the external fault 2, Perform motor ID auto tuning 3, Increase the acceleration time 4, Adjust voltage of power supply to normal 5, Cancel the suddenly adding load 6, Install braking unit or braking resistor
Over current in constant speed running	Err04	1, The inverter output short circuit or phase to ground 2, No performance ID auto tuning for carrying vector control 3, The voltage of grid is low 4, Whether there is a sudden load in running 5, The using Inverter capacity (rated power is small)	1, Excluding the external fault 2, Perform motor ID auto tuning 3, Cancel the sudden loading 4, Cancel the suddenly adding load 5. Select big power inverter instead
Over voltage in acceleration	Err05	1, The input voltage is high 2, The acceleration process there is an external drag motor running 3, The acceleration time is too short 4, No brake unit and brake resistor	1, Adjust voltage to the normal range Cancel the additional force or install braking resistor 3, Increase the acceleration time 4, Install the braking unit or braking resistor
Deceleration overvoltage	Err06	1, The input voltage is high 2, The process of deceleration	1, Adjust voltage to normal range

		there is an external drag motor running 3, Deceleration time is too short 4, No brake unit and brake resistor	2, Cancel the additional force or install braking resistor 3, Increase acceleration time 4, Install the braking unit or braking resistor
Over voltage in constant speed	Err07	1, Input voltage is high 2, The process of deceleration there is an external drag motor running	1. Increase voltage go normal range 2. Cancel external force or install braking resistor
Fault of control section power supply	Err08	1. Input voltage is out of limit	Adjust voltage to normal range
Under voltage fault	Err09	1, Instantaneous power failure 2, Input voltage is out of limit DC bus voltage is abnormal 4, rectifier bridge and buffer resistance is not normal	1, Reset the fault 2, Adjust the voltage to the normal range 3, seek technical support
Inverter over load	Err10	1.. If load is too big, or motor is blocked or not 2. Using inverter capacity is too small	1. Reduce the load and check the motor and machine condition 2. Select bigger one capacity of motor
Motor overload	Err11	1, The motor protection parameter P9-01 set is appropriate 2, The load is too large or motor is blocked 3, Using the power of inveter too small	1. Set correct parameter 2. Reduce load or check motor and driving machine 3. Select bigger power inverter
Input phase loss	Err12	1, Three-phase input power is not normal 2, The driving board exception 3, Lightning board abnormalities 4, The main control board exception	1, Check and eliminate the problems in the external lines 2, Seek technical support
Output phase loss	Err13	1, The inverter wiring is damaged 2, 3 phase output is not balance of inverter when motor running 3, Driving board is abnormal 4, IGBT model is abnormal	1, Excluding the external fault 2, Check the motor three-phase winding is normal and troubleshooting 3, seek technical support
IGBT module is over heat	Err14	1, The ambient temperature is too high 2, Air duct blockage 3, The fan is damaged 4, IIGBT module thermistor is damage 5, The inverter module is damaged	1, Reduce the ambient temperature 2, Clean up the duct 3, Replace the fan 4, Replace the thermistor 5, Replace the inverter module
External device fault	Err15	1, Through the multi-function terminal DI input external fault signal 2, Through the virtual IO function input external fault signal	1, Reset 2, Reset

communication fail	Err16	1, The host computer is not working properly 2, The communication line is not normal 3, Communication parameters PD group settings are not correct	1, Check the host computer wiring 2, Check the communication cable 3, Set the communication parameters correctly
Contactore failure	Err17	1, The driving board and power supply is not normal 2, Contactor is not normal	1, Replace the inverterboard or power board 2, Replace the contactor
Current detection failure	Err18	1, Check the Hall device exception 2, The driving board exception	1, Replace the Hall device 2, Replace the driver board
Motor tuning fault	Err19	1, The motor parameters are not set by nameplate 2, Parameter identification process timeout	Set motor parameters according to motor nameplate
Encoder fault	Err20	1, The encoder model does not match 2, The encoder connection error 3, The encoder is damaged 4, PG card exception	1, Check the encoder parameters 2, Excluding line wiring failure 3, Replace the encoder 4, Replace the PG card
EEPROM read and write failures	Err21	1, EEPROM IC broken	1, Replace the controller board
Inverter hardware failure	Err22	1, there is overvoltage 2, there is overcurrent	1, trouble shooting as over voltage 2, trouble shooting as over current
Short to ground	Err23	1, Motor to ground short circuit	1, Change motor cable or motor
The cumulative run time arrives	Err26	1, The cumulative run time is over the set the value	1, Clear the record with parameters initialization
User Defined Fault 1	Err27	1, User define fault signal 1 with multi-function terminals. 2, User define fault signal 1 with virtual IO function	1, Reset 2, Reset
User Defined Fault 2	Err28	1, User define fault signal 2 with multi-function terminals. 2, User define fault signal 2 with virtual IO function	Reset Reset
The cumulative power up time arrives	Err26	1, The cumulative power up is over the set the value	1, Clear the record with parameters initialization
Load missing	Err30	1, The running current of inverter less than P9-64	Check the load condition
PID feedback loss	Err31	1, PID feedback value less than PA-26	Check the PID feedback signal or set PA-26 value correct
wave by wave current limit fault	Err40	1, The load is too large 2, The inverter selection is too small	1, Check the load 2, Zoom in the inverter power level;
Motor	Err41	1. Change the current motor	Switch motor in stop mode

switchover fault		selection through the terminal during the inverter operation	of inverter
The speed deviation is too large	Err42	1, The encoder parameter setting is not correct 2, No perform motor auto tuning 3, The speed deviation is too large , P9-69, P9-60 setting is unreasonable	1, Correct set encoder parameters 2, Motor auto tuning 3, Set correct value for P9-69, P9-60 per filed condition
A.SLP	81	Sleep mode	To check if enough total solar power input, the total power of solar arrays should bigger 1.3 times of rated power of pumps. 2.To check if enough DC Vmp, recommend 1.41 times DC voltage ofAC pumps voltage 3. Increase the PE-04 and PE-05MPPT gain value 4. To check PE-16sleep voltage if correct to set.
A.LFr	82	Low frequency protection	If the output frequency is lower PE-19 setting,this alarm will be activated for pumps protection. please set PE-19 for low value if need.
A.LLd	83	Dry run/under load protection	Set PE-22 for lower value to disable this alarm.
A.OLd	84	Over current/ over load protection	Set over current PE-25 for low or set for 0.
A.LPr	85	Minimum power	Set PE-28minimum power input protection for lower
A.FuL	86	Water tank fulling	To check if water is fulling
A.Prb	87	Analog sensor problem failure	To check if the sensor is broken or set PE-35for lower
Err.98	98	Distributor running time reach	Contact distributor
Err.99	99	Factory running time reach	Contact manufacturer

Chapter 11 SU200 RS485 communication protocol

11.1 Communication protocol

SU200 series solar pump inverter can select the RS485 communication interface. The international standard ModBus communication protocol is adopted for master-slave communication. The consumer can carry out centralized control by PC/PLC, upper machine, main station solar pump inverter etc (Setting of the solar pump inverter control command, running frequency, relative function parameters modification, solar pump inverter working state and malfunction information monitoring etc.. to adapt to the special application requirements.

11.2 Protocol content

This ModBus protocol defines the information content and format of asynchronous transmission in series communication. It includes: host machine polling, broadcast and the format of slave machine response. Host machine data frame includes: slave machine address (or broadcast address), ask action code, data and fault check. Slave machine response is same structure: action check, back data and fault check. If slave machine meet fault while accept frame, or can't compete the action asked, fault information will be feed back to host machine.

11.3 Application mode

SU200 series solar pump inverter has control network for "single host machine and many slave machines" with R2S32/RS485. Remote RS485 communication needs shield cable and shield grounding. For long distance communication, we suggest to open J6 and add 120Ωresistance to prevent signal reflection.

11.4 Main line structure

- 1, Port mode: RS485 port
- 2, Transmission mode: Asynchronous series, half duplex transmission mode. At same time, one of the host machine and slave machine sends data, another receives data. Data is sent one by one frame as report form in asynchronous series communication.
- 3, Topological structure: One host machine with several slave machines. Range of slave machine address is 1 to 247. 0 is broadcast address. Every slave machine address is only one. It is the base of ModBus series communication.

9.5 Protocol explain

SU200 series solar pump inverter communication protocol is main-slave ModBus communication protocol of asynchronous series. In the net, only the host machine can set up protocol "inquire/ order". Slave machines can only respond to host machine. Host machine means PC, main solar pump inverter, industrial control equipment or PLC...

Slave machines are SU200 solar pump inverters and other control equipments with same communication protocol. Host machine can communicate with only one slave machine or broadcast to all slave machines. Slave machine need feedback every "inquire/order" of host machine, but no need feedback broadcast.

9.5.1 Communication frame structure

The ModBus protocol communication data format of SU200 series solar pump inverter is RTU (remote terminal unit) mode. Communication data format is as follows:

The byte composition: Include initiation bit, 8 data bit, check bit and stop bit.

Initiation bit	Bit 1	Bit 2	Bit 3	Bit 4	Bit 5	Bit 6	Bit 7	Bit 8	No check bit Even check bit Odd check	stop bit
----------------	-------	-------	-------	-------	-------	-------	-------	-------	---	----------

In RTU mode, it always starts after at least 3.5 byte transmission time which is easy realized under Baud rate. And next data is: slave machine address, operation order code, data and CRC check.

Every domain transmission is hexadecimal 0...9 , A...F. Network equipment detects the network bus unceasingly, including the interval time. While receiving the first domain (address information, each network equipments carry out decoding to judge whether the byte is for itself. While the final byte transmission is completed, there will be at least 3.5 bytes transmission time interval to indicate that this frame is over. Then a new information' transmission can begin

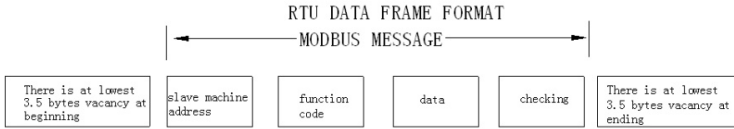

One frame message must be transmitted as a continued data flow. If there is a pause over 1.5 byte before the end, the receiving equipment will clear the half-baked information. And the next byte will be considered as the address domain of a new frame. Similarly, if the interval between a new frame start-up and the former frame is smaller than 3.5 byte time, the receiving equipment will think that it is the former one frame continuation. Because of the jumbled frame, finally CRC checking value is incorrect, what leads to the communication mistake.

Frame start	The transmission time of 3.5 bytes in silent
Slave address ADDR	0~247(0 broadcast address)
Executive command MD	03H : Read slave parameters 06H : Write slave parameters
Function code H	Inverter inside parameters, divided into functional code and non-functional patterns (such as operating status parameters, run the command, etc.) parameters, see the address definition.
Function code L	When transmitting, the high byte is preceded by the low byte in the post.Hexadecimal representation
Function code H	The number of function codes read by this frame, if 1 is to read a function code. When transmitting, the high byte is preceded by the low byte in the post.
Function code L	This protocol can only rewrite a function code at once, without this field
Data H	The data to be answered, or the data to be written, is transmitted when the high byte is preceded by the low byte in the post.
Date L	
CRC CHK high byte	Detection value: CRC16 check value. When transmitting, the high byte is preceded by the low byte in the post. The calculation method is described in the CRC check in this section.
CRC CHK low byte	
END	3.5 characters

RTU frame's standard structure

CRC check mode --- CRC (Cyclical Redundancy Check)

Use RTU format, frame include Framing Error detection domain calculation method based on CRC. CRC field checks the contents of the entire frame. CRC field is two bytes, containing a 16-bit binary. After it is calculated by the transmission equipment is added to the frame. The receiving device receiving the frame recalculate the CRC, and compared with the value received in the CRC field, if not equal, then the transmission errors.

CRC is first stored in 0xFFFF, then calls a procedure in the frame byte and the value of the current register for processing. Only 8Bit data for each byte CRC is valid, the start and stop bits and the parity bits are invalid.

CRC generation process, each 8 bytes are separate and distinct register contents or (XOR), the result moves to the least significant bit direction, the most significant bits padded with 0s. LSB is extracted detect if LSB is 1, the preset value register individually and XOR, if LSB is 0, no. The whole process is repeated eight times. After the last (eight), the next 8-bit byte is exclusive content dissimilar or register. The final value of the register is CRC value of the frame in all bytes after the execution.

CRC This calculation method using the international standard CRC check rules, the user when editing CRC algorithm, can refer to the relevant standard CRC algorithm to write a CRC calculation program really meet the requirements.

CRC now offers a simple function to calculate the user's reference (C programming language):
 unsigned int crc_cal_value(unsigned char *data_value, unsigned char data_length)

```
#define uint    unsigned int
#define uchar  unsigned char
```

```
uint crc_chk_value(uchar *data_value , uchar length)
```

```
{
    uint crc_value ;
    int i ;

    crc_value = 0xFFFF
    while(length --)
    {
        crc_value ^= *data_value ++ ;
        for(i=0;i<8;i++)
        {
            if(crc_value & 0x0001)
            {
                crc_value = (crc_value >> 1) ^ 0xA001 ;
            }else
            {
                crc_value = crc_value >> 1 ;
            }
        }
    }
    return crc_value ;
}
```

Function Code Parameter Addressing Rules:

With the function code group number and label for the parameter address that rules:

High byte: P0 ~ PF (group F), 70 (U group); low byte: 00 ~ FF

For example, if the range function code P3-12 is to be used, the access address of the function code is represented as 0xF30C;

Note: PF group parameters: neither read nor change; U group: only read, can not change the parameters.

Some parameters can not be changed when the inverter is running. Some parameters can not be changed regardless of the state of the inverter. Change the function code parameters and pay attention to the range, unit and description of the parameters.

Function code	Communication access address	Communication Modifies the function code address in RAM
P0 ~ PE group	0xF000 ~ 0xFEFF	0x0000 ~ 0x0EFF
U0 group	0x7000 ~ 0x70FF	Can't modify

Note: Because EEPROM is frequently stored, will reduce the EEPROM's life, so some function code in the communication mode, no need to store, just change the value of RAM on it. If the P group parameters, to achieve this function, as long as the function code address high F to 0 can be achieved.

The corresponding function code address is as follows:

High byte: 00 ~ 0F (group F); low byte: 00 ~ PF

For example: Function code P3-12 is not stored in the EEPROM, the address is expressed as 030C; the address that can only write RAM, can not read the action, read, for the invalid address.

For all parameters, you can also use the command code 07H to achieve this function.

Shutdown / Run Parameters Section:

Monitor parameters	Monitoring contents	Unit	Address
U0-00	Running frequency (Hz)	0.01Hz	7000H
U0-01	Setting frequency (Hz)	0.01Hz	7001H
U0-02	DC voltage of PV arrays (V)	0.1V	7002H
U0-03	Output voltage (V)	1V	7003H
U0-04	Output current (A)	0.01A	7004H
U0-05	Power of PV arrays(KW)	0.1KW	7005H
U0-06	Current of PV arrays (A)	0.01A	7006H
U0-07	DI input status	1	7007H
U0-08	DO output status	1	7008H
U0-09	A11	0.01V	7009H
U0-10	A12	0.01V	700AH
U0-11	KAI	0.01V	700BH
U0-12	PV open loop circuit voltage	0.1V	700CH
U0-13	Flow rate of pump	0.1m ³ /hr	700DH
U0-14	Day flow	0.1m ³	700EH
U0-15	Flow accumulation (low-order digit)	0.1m ³	700FH
U0-16	flow accumulation (low-order digit)	0.1Km ³	7010H
U0-17	Day generated power	0.1kwh	7011H
U0-18	Generated accumulation (low-order digit)	0.1kwh	7012H
U0-19	Generated accumulation (high-order digit)	0.1Mwh	7013H

Note:

1. Communication set frequency is the percentage of relative value, 10000 corresponds to 100.00%, - 10000 corresponds to -100.00%.

2. For the data of the frequency dimension, the percentage is the percentage of the relative maximum frequency (F0-10)

3. For the data of the torque dimension, the percentage is P2-10 (torque upper limit digital setting).
Control command input to Invert: (write only)

Address of command	Command function
2000H	0001: Forward
	0002: Reverse
	0003: Jog forward
	0004: Jog Reverse
	0005: Free stop
	0006: Deceleration
	0007 : Fault reset

Read the Inverter status: (read only)

Status word address	Status word function
3000H	0001: Forward run
	0002: Reverse run
	0003: Stop

Parameter lock password verification: (if returned to 8888H, that means that password verification)

Password address	Enter the contents of the password
1F00H	*****

Digital output terminal control: (write only)

Command address	Command contents
2001H	BIT0: DO1 output control BIT1: DO2 output control BIT2: RELAY1 output control BIT3: RELAY2 output control BIT4: FMR output control

Analog output AO1 control: (write only)

Command address	Command contents
2002H	0 ~ 7FFF means 0% ~ 100%

Analog output AO2 control: (write only)

Command address	Command contents
2003H	0 ~ 7FFF means 0% ~ 100%

Pulse (PULSE) Output Control: (write only)

Command address	Command contents
2004H	0 ~ 7FFF means 0% ~ 100%

Inverter fault description:

Inverter fault address	Inverter fault information	
8000H	0000: No fault 0001: Reserved 0002: Accelerated overcurrent 0003: Deceleration overcurrent 0004: constant speed	0015: Parameter read and write exception 0016: Drive hardware failure 0017: Motor to ground short circuit fault 0018: Reserved 0019: Reserved

	overcurrent 0005: Accelerated overvoltage 0006: Deceleration overvoltage 0007: constant speed overvoltage 0008: Buffer resistance overload fault 0009: Undervoltage fault 000A: Inverter overload 000B: motor overload 000C: Input phase loss 000D: Output phase loss 000E: module overheat 000F: External fault 0010: communication error 0011: contactor is abnormal 0012: Current detection fault 0013: Motor tuning fault 0014: Encoder / PG card fault	001A: Run time arrives 001B: user defined fault 1 001C: User Defined Fault 2 001D: Power-up time arrives 001E: Drop 001F: Runtime PID feedback lost 0028: Fast current limit timeout 0029: Motor is switched at runtime 002A: The speed deviation is too large 002B: motor speed 002D: motor overtemperature 005A: Encoder line setting error 005B: Missed encoder 005C: initial position error 005E: Speed feedback error
--	---	--

Information description data (fault code):

Communicati on fault address	Fault function description	
8001H	0000: No fault 0001: Password is incorrect 0002: Command code error 0003: CRC check error 0004: Invalid address	0005: invalid parameter 0006: parameter change is invalid 0007: The system is locked 0008: operating in EEPROM

PD group communication parameter description

Pd-00	Baud rate	Factory default	6005
	Set range	Bit: MODBUS baud rate 0 : 300BPS 5 : 9600BPS 1 : 600BPS 6 : 19200BPS 2 : 1200BPS 7 : 38400BPS 3 : 2400BPS 8 : 57600BPS 4 : 4800BPS 9 : 115200BPS	

Pd-01	Data Format	Factory default	0
	Set range	0: No parity: Data format <8, N, 2> 1: Even test: Data format <8, E, 1> 2: Odd parity: data format <8, O, 1> 3: No parity: Data format <8-N-1>	

Pd-02	Local address	Factory default	1
	Set range	1 ~ 247 , 0 is the broadcast address	

When the local address is set to 0, that is, broadcast address, to achieve the host computer broadcast function.

The local address is unique (except for the broadcast address), which is to achieve the host computer and the inverter point to point communication basis.

Pd-03	Response delay	Factory default	2ms
	Predetermined area	0 ~ 20ms	

Pd-04	Communication timeout	Factory default	0.0 s
	Set range	0.0 s (invalid) 0.1 ~ 60.0s	

When the function code is set to 0.0 s, the communication timeout parameter is invalid. When the function code is set to a valid value, the system will report a communication error (Err16) if the interval between the next communication and the next communication exceeds the communication timeout period. Normally, it is set to invalid. If you set the secondary parameter in a continuous communication system, you can monitor the communication status.

PD-05 = 1: Select the standard Modbus protocol.

PD-05 = 0: When reading a command, the number of bytes returned by the slave is one byte more than the standard Modbus protocol.

Used to determine the output unit of the current value when the communication reads the output current.

Pd-05	Communication protocol selection	Factory default	0
	Set range	0: non-standard Modbus protocol 1: Standard Modbus protocol	